



AMERICAN PAINT HORSE ASSOCIATION
BOARD OF DIRECTORS
MEETING MINUTES
Grapevine, Texas
June 1, 2013

- V. Introduce Jan Anderson to call roll Gregg

Jan announce - prior to roll call

Will alternates voting in the absence of their area's director raise your hand? A signature card will be brought to you.

After Roll Call - Ask if any names were missed.

Announce: Directors and alternates not installed at convention will be installed at this time. Jan Anderson

Administer Oath of Office.

- VI. Installation of 2013 Board of Directors Jan Anderson

- VII. I now want to Introduce the **AJPHA President Elect Kaitlyn McCulley who will present her presidential project** Gregg

- IX. **Approve Minutes** of October 5-6, 2012 Board of Directors Meeting Gregg

I need a motion to approve the minutes of the October 5-6, 2012 Convention Board of Directors meeting.

- X. **Ratification of Executive Committee Actions** Gregg

Resumes are in your booklet for the Executive Committee meetings from **October 2012 through March 2013**

I need a motion to ratify Executive Committee actions.

- XI. Present Farnam Breeder's Trust Scholarship Club presentations Billy

APHA and Corporate Partner Farnam Horse Products recently drew winners of a new youth scholarship program designed to support the youth of the APHA, promote the Breeders' Trust program, and encourage APHA regional clubs to create outreach programs to local equine youth groups.

Two \$1,000.00 scholarships are being awarded this year, and AjPHA members became eligible for these scholarships by showing Breeders' Trust-nominated horses in APHA youth or novice youth classes during the qualifying period of April 1, 2012–March 31, 2013. Entries were earned by exhibiting in any APHA-approved event where Breeders' Trust points were earned. Each youth who showed a Breeders' Trust-nominated horse in a youth class earned one entry into the scholarship sweepstakes per judge, per class. In addition to the youth receiving the scholarship, each recipient was asked to select a regional club from

their home state to receive \$500 to fund an outreach program to local youth equine programs.

This year's youth all-ages exhibitor scholarship recipient is Anne-Marie Fortenberry from Louisiana, and the novice youth exhibitor scholarship recipient is Tiffany Payne from Cedar Falls, Iowa. These young ladies will be presented with their scholarships at the Youth Awards Banquet at the AjPHA Youth World Championship Show in June; however, we would like to recognize and award their chosen clubs today.

We have Farnam representative Ms. Sharon Bonner-Brown with us today, and I would like to call on her to present these \$500 checks....

All-ages winner Anne-Marie Fortenberry selected the Louisiana Paint Horse Club represented today by Mary Parrott.

And novice winner Tiffany Payne selected the Iowa Paint Horse Club represented today by Gregg Reisinger.

The 2013/2014 qualifying period began April 1. Please encourage your youth club members to take part in this great new scholarship program. Special thanks to APHA Corporate Partner Farnam for its continued support.

- XII. Regional Club Sponsorship Award presentation. Billy
Presentor Gregg
Recipients
Albert PHC
Mid South PHC - Jimmy Harrison
North George PHC - Ann Jones
Northern California PHC – Travis Titlow
Oklahoma PHC – Mike Short
Paint Horse Club Czech Republic
PHC Italia
Texas PHC – Renee Robinson

- XIII. Show Rules Task Force Gregg

I need a motion to support the creation of a Show Rules Task Force, and after committee review and comment, their findings will go to the EC for consideration and possible approval of these rule changes to take effect January 1, 2014.

- XIV. Presentation of Financial Report Rosemary Teate

XV. Old Business Gregg

Ask if there is any old business to come before the Board of Directors.

XVI. New Business Gregg

Ask if there is any new business to come before the Board of Directors.

XVII. I'll now ask for the Standing Committee Reports and the Presentation of Rule Change Proposals for amendment – these are in the Workshop booklets. Only those that were passed in committee will be read out by the Chairs. In the booklet, all proposals were listed, but if not read out, it means they were defeated in committee.

The Standing Committees will present the rule change proposals for amendment. **Please be reminded that this will be your only opportunity to amend these rules.** The Rule changes as proposed here will be published in the *Paint Horse Journal* and forwarded for vote at Convention 2014. Please turn in your meeting minutes and report (both handwritten and typed versions) to Jan Anderson before leaving this meeting.

Committee	Chair
Rules	Jean Fell
Registration	Sharon Bonner-Brown
Gen. Show & Contest	Mark Kuhlwein
Judges	David Denniston
Amateur	Melanie Cox-Dayhuff
Youth	Sue Woodson
Long Range Planning	Don Beard
Membership Services	Jackie Mellon
Professional Horsemen	Gerald Butler
Racing	Pancho Villarreal
Recreational Riding	Anita Hertner
Regional Club	Lori Nevin
Ways & Means	Linda Gordon
APH Foundation	Linda Gordon, APHF president
EC Nominating Committee	Carl Thurow

XVIII. Closing remarks - adjourn

**American Paint Horse Association
Board of Directors Minutes
Workshop Meeting
Hilton Lakes DFW
Grapevine, Texas
May 30-June 1, 2013**

Call to Order – Gregg Reisinger, APHA President.

The Board of Directors meeting was called to order at 8:45 a.m. at the Hilton Lakes DFW in Grapevine, Texas on Saturday, June 1, 2013. Past President Carl Thurow was asked to give the invocation.

Introductions and Speakers.

APHA Past Presidents were introduced, as well as members of the current APHA Executive Committee. Special guest Pat Mullins with corporate sponsor Markel Insurance was recognized as an honored guest as was California director Steve Nash, representing corporate sponsor Farnam.

Roll Call and Oath of Office – Anderson.

The president asked Executive Assistant Jan Anderson to call the roll. *See Appendix A.* Anderson also gave the Oath of Office to those directors not installed at the October, 2012, convention meeting.

Association Progress Report.

The Board of Directors met in a preliminary meeting on Friday, May 31, 2013, during which time Executive Director, Billy L. Smith, gave a Progress Report with updates and highlights of the past year. He emphasized that APHA's plan for the next few years is to focus on revenue, productivity and loyalty. He reported that the membership campaign has helped stabilize membership, which had been experiencing losses of 10,000-15,000 per year, while only 3,000 members were lost in 2012.

Other positive statistics cited were 38,000 new show entries from 2011 to 2012; six months of increased registrations, an increase in number of horses sold at the Farnam WYO sale from 5 to 21; a 2% increase in youth membership; and, finally, \$50,000 will be offered in the Farnam WYO class at this year's World Show.

Smith noted the launch of APHA Xtras, a generous package of benefits for members that will save members more than the cost of membership. Also launched recently was the first issue of *Chrome*, the new APHA member magazine.

The Board was reminded by Smith of the eight top priorities for 2013. Those priorities are to reduce the payroll burden; reengineer business processes; increase corporate partnership appearance; upgrade technology for improved efficiency; continue becoming revenue centric; improve the communication process; improve Breeders' Trust program payouts and participation; and balance the operations budget for 2014.

Smith touched on other areas, citing the number of Facebook fans reaching over 100,000; the awarding of almost \$50,000 in youth scholarships through the Foundation; the formation of the *Paint Horse Journal* Elite Team and increased loyalty to that publication, up almost \$85,000, and a growing satisfaction with overall judging at the World Show.

Smith closed his presentation by challenging the committees to talk about making an impact on the horse industry and not just an impression, to think big and far down the road.

* * * * *

Chairs and Vice Chairs of Standing Committees met with the Executive Committee immediately following the Executive Director's report. President Reisinger asked the committees to report back with input and feedback from their committees and members in their areas concerning a proposed participating licensing, green classes to be held during the Open/Amateur World Championship Show, and youth qualifications for the Youth World Championship Show (continued requirements to qualify or not, and/or modified requirements.)

* * * * *

AjPHA Presidential Service Project.

Reisinger introduced AjPHA officers and AjPHA President-Elect Kaitlyn McCulley, who presented her presidential service project, "*Bring It Home*", the goal of which is to create more AjPHA Youth Scholarships. The idea is to attract more youth participation and to create more members, which will grow the Association. If asked why, McCulley said that past presidential service projects have helped outside organizations such as *Make a Wish* and *MDA, Wounded Warriors* and *St. Jude and therapeutic riding*; however, while these are all wonderful projects and have been helpful, McCulley said she wanted to bring it back to the association and improve ourselves before helping others. With AjPHA memberships down by 200 members since last year, she felt her goal should be to attempt to increase youth membership.

After talking with the youth director and others, it was decided it would be best solution would be to try to complete already existing scholarship endowments started within the Foundation; they would then be able to be endowed and a \$1,000 scholarship could be issued every single year. It will also be tax deductible. There are 22 endowments that were started and never completed; the amounts vary as to what is needed to complete them. Over the years, the amount to fund an endowment has increased from \$10,000 to the current \$25,000. A total of \$186,000 would be required to fulfill the various incomplete scholarships, but McCulley stated her plan is to just work on one at a time, beginning with the regional and/or oldest ones. She asked for help in supporting the future of our youth and explained how donations can be made by sending a check to the Foundation and specifying that it goes toward this project.

* * * * *

Approval of Minutes and Ratification of EC Actions.

President Reisinger asked for a motion to approve the minutes of the October, 2012 convention meeting of the Board of Directors.

Motion #1: It was moved and seconded to approve the minutes as circulated. Motion passed.

A motion was also requested to ratify the actions of the Executive Committee from October of 2012 through April of 2013.

Motion #2: It was moved and seconded to ratify the actions of the APHA Executive Committee from October, 2012 – April, 2013, with the exception of one action taken by the Executive Committee from the March 8-9, 2013, Regular EC minutes, i.e., "a change to the Breeders' Trust to require a \$100 fee every other year after six years of age for all nominated Breeders' Trust horses, with the owners receiving an invoice, to be implemented in 2014.", which was not ratified. Motion passed. *See Appendix B.*

Note: Since this action was not ratified by the Board of Directors, it will be so noted in the original March 8-9, 2013, EC minutes of that meeting.

* * * * *

Presentation of Farnam Breeders' Trust Scholarships – Smith.

APHA and Corporate Partner Farnam Horse Products recently announced winners of a new youth scholarship program designed to support the youth of the APHA, promote the Breeders' Trust program and encourage APHA regional clubs to create outreach programs to local equine youth groups.

Two \$1,000 scholarships are being awarded this year, and AjPHA members became eligible for them by showing Breeders' Trust nominated horses in APHA youth or novice youth classes during the qualifying period of April 1, 2012-March 31, 2013. Entries were earned by exhibiting in any APHA-approved event where Breeders' Trust points were earned. Each youth who showed a Breeders' Trust-nominated horse in a youth class earned one entry into the scholarship sweepstakes per judge, per class. In addition to the youth receiving the scholarship, each recipient was asked to select a regional club from their home state to receive \$500 to fund an outreach program to local youth equine programs.

This year's youth all-ages exhibitor scholarship recipient is Anne-Marie Fortenberry from Farmerville, Louisiana, and the novice youth exhibitor scholarship recipient is Tiffany Payne from Cedar Falls, Iowa. These young ladies will be presented with their scholarships at the Youth Awards Banquet at the AjPHA Youth World Championship Show in June but are hereby recognized and the clubs they chose will be awarded their cash awards today. Sharon Bonner-Brown with Farnam presented checks to Mary Parrott and Sue Woodson, who represented the Louisiana PHC selected by Anne-Marie Fortenberry; and, Gregg Reisinger and Jerry Cable who represented the Iowa PHC, selected by novice winner Tiffany Payne

Smith noted the 2013-2014 qualifying period* began April 1 and asked the Board encourage its youth club members to take part in this great new scholarship program. Special thanks were given to APHA Corporate Partner Farnam for its continued support.

Note: The Executive Committee voted to discontinue Youth World Show qualifying for 2014, after receiving additional feedback, at its July 3, 2013 regular meeting.

Regional Club Sponsorship Award Presentations – Smith.

The representatives listed below picked up the \$500 awards for their club as stated below:

- Alberta PHC – will be mailed
- Mid South PHC – Jimmy Harrison
- North Georgia PHC – Lisa Westmorland
- Northern California PHC – Gwen Melshaw
- Oklahoma PHC – Mike Short
- Texas PHC – Renee Robinson
- PHC Czech Republic – will be mailed
- PHC Italia – will be mailed

* * * * *

Show Rules Task Force – Reisinger.

President Reisinger called for a motion to support the creation of a Show Rules Task Force, and after committee review and comment, their findings will go to the Executive Committee for consideration and possible approval of these rule changes to take effect January 1, 2014.

Motion #3: It was moved and seconded to approve the formation of a Show Rules Task Force, with the group's findings going to the appropriate standing committees and finally to the Executive Committee for consideration and possible approval of these proposed rule changes, to take effect January 1, 2014. Motion passed.

* * * * *

Financial Report – Teate.

Senior Director of Accounting Rosemary Teate was asked to give the directors a financial report. Teate stated that the directors would be informed of the following: 2012 Financial Results; 2012 Revenue by Major Departments; Statement of Financial Position; 2012 Operating Results – Open & Amateur World Show & Gift Show; Comparison of Operating Results – Open & Amateur World Show & Gift Show – 2011 vs. 2012; 2012 APHA Farnam Breeders' Trust Select Sale Results; and the Operating Results – January-April, 2013. *See Appendix C.*

Teate explained the slides presented and then concluded her report with the following summary: Cultural and organizational transformation is underway that is leading to significant improvements in thinking, approaches, processes and productivity across the organization. The foundation is being formed to positively influence and affect future outcomes.

Careful reductions in force have been made to streamline staff and reduce fixed salaries and employee-related expenses going forward. The reductions in force were complemented with certain strategic upgrades in personnel. Attitudes and overall morale continue to improve as organization experiences a series of small wins and begins seeing a clear way forward.

Making greater use of contract labor for specific and specialized project-oriented tasks, to expand capacity and productivity when needed (without adding fixed payroll costs) is ongoing.

A sharp eye is being kept on spending with the recognition that strategic investments are required to fuel a broad-based turnaround.

Staff is actively seeking opportunities to grow existing revenue streams and develop new revenue streams; identifying programs and services that need to be fixed or eliminated; investing to fully automate as many APHA transactions as possible to make interactions with APHA more efficient and satisfactory than ever before, while creating the capacity for a more high touch environment for any member who desires that level of attention; making steps to further improve forecasting, budgeting and reporting; becoming more and more aware of organizations having a negative impact on APHA revenue and competing more and more aggressively

to protect and grow APHA revenue. Teate thanked the directors for their continued support and asked for any questions.

* * * * *

A question was raised as to why NRHA moved its Cowtown Classic out of Fort Worth and was it due to the loss of the senate trust fund money. Smith responded that while the show was pulled, he did not feel it was the only reason it was pulled; however, there was a bill before the Texas legislature that caused concern earlier in the year. That proposed bill was addressed by both NCHA and City of Ft. Worth as well as the APHA. A stronger bill resulted and secured our place as to future funding, possibly not creating more money but allowing the fund to remain in place for us. It required some legislative jumping through hoops and maneuvering, but the final bill gives the city more flexibility in administering the program.

A question was asked as to how the money would be addressed now that we have joined with Appaloosa for the youth show. Smith said they are filed separately as two events and funded separately, possibly being a benefit to both groups by increasing the number of participants.

Staff was commended for its efforts to reduce expenses and a question was asked about the proposed changes to the Breeders' Trust sale. Smith explained that the sale rules will now permit a reserve as in the past, but if the reserve is not met, there will be payment made against the last bid; it will make the reserve process more transparent.

A question was asked about corporate sponsors and what has created concern about joining with APHA. Smith stated that sponsors want increased credibility for their product and, through some past events, APHA has not earned that for them. However, potential sponsors have also indicated that they want to pay close attention to APHA; APHA members need to support sponsors because that will help with the credibility issues. Smith asked that members participate with sponsors if they can use these benefits and it is of help to them. Staff will try to fulfill the sponsorships as best as possible, but sponsors expect a return on investment, and we are trying to give members value. If members can take advantage of them, then everyone will benefit.

Old or New Business – Reisinger.

The president asked if there were any other old or new business. There was none; Reisinger then called for the committee reports, during which those rule change proposals that were passed in committee will be read out. The Board was reminded that this will be their only opportunity to amend these rules. The proposals as presented here will be published and forwarded for vote at the 2014 Convention.

Standing Committee Reports – Committee Chairs, Vice Chairs or representatives.

The Standing Committees were asked to report on committee meetings and announce the rule change proposals which were brought out of committee. All Standing Committee Reports will be published in the Summer *Paint Horse Connection* and the rule changes are published on the website at www.apha.com/Forms and Downloads/Rule Books. *See Appendix D.*

Amateur

Attending the meeting were the following: Chair Melanie Cox-Dayhuff, Vice Chair Jan Mannion, Fred Cole, Jimmy Harrison, Sue Johnson, Stacie Lundquist, Judy Moyer, Wendy Noder, Robin Robinett, Elizabeth Roberts-Brewer, Wesley Siebbenicher, Nina Skinner, Annie Suratt and Ike Swafford. Staff Shelly

deBarbanson was also present. The committee discussed 13 rule change proposals. Among those that were defeated were proposals to require show management to combine classes if one division is not a two-point class; changing the Amateur divisions to 19-49 and 50 & Older; changing the point requirements for Novice Amateur eligibility; and permitting the use of horses not owned by the Amateur in the Novice Amateur division.

Rule change proposals passed by the committee for consideration at the 2014 Convention include: permitting amateur leasing in all zones, in addition to the original rule change proposal that would permit amateur leasing in international zones; providing awards for Limited Working Ranch Horse; changing reinstatement for Novice eligibility to allow 10 or more APHA or revalued points; making Novice Amateur Working Cow Horse a boxing-only class; requiring Amateur Walk-Trot exhibitors to choose which showmanship class in which they will exhibit at a show; adding Top 10 Amateur Walk-Trot year-end and zone awards; and allowing Amateur Walk-Trot exhibitors to show non-owned horses.

Furthermore, the committee was in favor of offering Green classes at the World Show as well as creating a judging rules task force. Regarding Youth World Show qualifying, the committee agreed changes might be beneficial, but did not think it should be eliminated. They also were in favor of participation-licensing and the development of a task force for further consideration—they did not believe licensed horses should have breeding rights, and believe it should be offered only to horses age 4 and older.

Breed Integrity & Registration Committee

The committee meeting was attended by the following: Vice Chair Sharon Bonner-Brown, Fred Adam, Craig Burkhard, Jerry Cable, I. J. Carey, Paul Garrett, Gary Gordon, John Hayden, Merle Himle, Renee Robinson, Cathy Sasser, Jennifer Sheriff, Jana Simons, Marie Ternes, Lisa Westmorland, and Earnest Wilson. Committee members discussed the Executive Committee's request for information on several topics. Although the committee understood some Youth had difficulty qualifying for the World Show due to weather and location of shows, they recommended qualifying rules remain the same.

Next, the group discussed pros and cons of offering Green classes at the World Show. Cons included awarding a "World Champion Green ..." title, which some believed didn't make sense because the intent behind the classes was to provide a forum for Green horses to compete against other horses of the same skill level, not to provide an opportunity for another world championship. Pros included the fact that there is little difference in a "World Champion Green ..." title than a "World Champion Novice ..." title. In addition, members noted that the Green classes have been very successful and offering them at the World Show would be financially beneficial for both members and the association. After much discussion, the committee recommended the association adhere to the current *Rule Book*, which states Green classes are not intended be offered at the World Show.

Regarding the Breeders' Trust, the committee recommended exhibitors continue to be compensated for points and did not agree with a point cap. They requested clarification of the Executive Committee's approval of a \$100 fee on Breeders' Trust horses over age 6 and of the expenses paid from the Breeders' Trust revenue available for distribution.

Billy Smith presented the concept of a participation-licensing program. The committee saw merit in exploring the possibilities of such a program, but did not see merit in defining a pathway to Regular Registry from a licensing program.

Two rule change proposals were discussed—allowing DNA testing to be used in determining Regular Registry status and allowing a less-restrictive color pattern for cropout registration. Both were defeated. The committee reviewed changes to the fee schedule, year-to-date statistics and financials.

Vice Chair Sharon Bonner-Brown conducted three round table discussions regarding threats to the Paint Horse breed, ways to make a difference in the one annual meeting environment, and reviewing a member-submitted proposal regarding Regular Registry criteria.

General Show & Contest Committee

The following attended the meeting: Chair Mark Kuhlwein, Vice Chair Ann Jones, Bruce Baker, Bonnie Christensen, Tom Gilmore, Peggy Ivins, Jay Jordan, Rick McLain, Linda Fick, Shannon Odell, Karen Roy, Charlie Sasser, Mike Short, Valera Snodgrass, Pat Trebesch and Alison Umberger. Staff Holly Slaughter also attended as well as nine guests. The committee met jointly with the Amateur, Youth and Judges committees to discuss related rule change proposals. The concept of a Judging Rules Task Force was introduced by George Ready and Dave Dellin. Billy Smith also introduced the participation-licensing concept and requested committees discuss it further in their meetings.

The Show & Contest Committee moved to support the creation of a Judging Rules Task Force; after committee review and comment, their findings will go to the Executive Committee for approval and will allow these rule changes to take effect January 1, 2014.

Forty-one rule change proposals were reviewed: 13 passed, eight were defeated and 20 rule change proposals were sent to the Judging Rules Task Force for further review.

World Show qualifying was discussed at length, and it was decided that modifications should be made to the requirements for the Youth World Show. This is due to the timing of the qualifying period and lack of show opportunities across the country during the winter, which prevents new Youth and/or Youth with new horses to get involved.

The committee recommended suspending the World Show qualifying requirement for the 2013 and 2014 Youth World Shows with modifications to the qualifying requirements to be developed and introduced for 2015 and after. The Open/Amateur World Show qualifying requirements should remain as is.

Upon the request of the Executive Committee, the possibility of offering Green classes at the World Show was discussed. The committee agreed adding the Green classes will increase entries and open up opportunities for new people to participate in the show.

The group moved to recommend that Green Western Pleasure, Green Western Riding, Green Trail and Green Hunter Under Saddle be added to the World Show effective in 2013 with qualifying waived for the current year. In addition, the committee moved to remove the wording “this class is not intended to be held at the World Show” from the *Rule Book* and asks that the Board of Directors approve this rule change with emergency status effective immediately.

Green class eligibility criteria was discussed in relation to Amateur Walk-Trot points counting. Confusion exists in the wording of the rule because Amateur Walk-Trot is not specifically listed as a class that counts, but does state that points from all divisions will count in determining eligibility. It was recommended that Amateur Walk-Trot points be excluded from the eligibility criteria effective in 2013.

The participation-licensing concept was discussed and determined to be a worthy concept to consider and could be a great revenue source for the association. The Show & Contest Committee supports the creation of a task force to study and develop the participation-licensing program.

The Breeders' Trust program was discussed at the request of the Executive Committee. It is the general consensus of the committee that a task force should be developed to do a thorough study of the program to determine how to increase participation and increase payouts.

Judges Committee

Those that attended the Exam meeting were as follows: David Denniston, Richard Cox, Kelly Chapman, Clint Fullerton, Linda Gordon, Don Manuello, Ron McMillian, Sandi Morgan, Rob Meneely, Karen Thomas, Lynn Titlow, Richard Waldner, Wayne Wall, Casey West and Larry Willard. In attendance during the standing committee meeting were: Chair David Denniston, Vice Chair Richard Cox, Vivian Beard, Kelly Chapman, Bill Englund, Clint Fullerton, Linda Gordon, Don Manuello, Ron McMillian, Rob Meneely, Karen Thomas, Lynn Titlow, Richard Waldner, Wayne Wall, Casey West and Larry Willard. The Judges Committee first met with the Amateur, Show & Contest and Youth Committees to discuss the Judging Rules Task Force, the participation-licensing proposal and rule changes.

Rule change proposal JU-000 was removed for consideration by the originator and placed on the agenda for the Judging Rules Task Force. It was further noted that the possible direction of this rule change might be to implement an "Ask A Judge" program instead of requiring presentation of reasons. Other related rule change proposals were discussed that pertain to the task force; suggested changes will be forwarded.

The list of new judges was handed out, and the location of the applicant exam was reviewed. This was the first year the exam took place in conjunction with AQHA, and it was determined to be a successful joint venture.

A discussion took place regarding Green classes at the World Show. Positives include additional entries and revenue; negatives involve giving world championship titles to Green-level horses and adding more classes in an attempt to give everyone a class to win. Vote was split 50/50 as to whether to offer Green classes at the World.

The participation license proposal was discussed. At first glance, the group believed it was a good idea. Concerns were expressed about allowing these animals to become breeding animals. It was suggested that if registration became an option, that it only be open to geldings. Confusion as to what disciplines would be covered was expressed. Some believed it would only be open to cattle, reining, speed and mounted shooting horses, while others thought that those were only suggested areas that would benefit from the program. Also expressed were concerns regarding whether or not this program will hurt Paint breeders by lowering the value of registered Paint Horses. The committee is curious to see more on this proposal but also expressed serious reservations.

In the closed meeting, 127 judges and two applicants were reviewed. Three variance requests were reviewed and voted on, and three Judges Committee policies were reviewed. The judges' application was reviewed and additional information requests will be added.

The committee discussed the formation of the Judging Rules Task Force and David Dellin asked for the support of the Judges Committee. A motion was approved to support the creation of a Judging Rules Task Force; after committee review and comment, their findings will go to the Executive Committee for approval and will allow these rule changes to take effect January 1, 2014.

Long-Range Planning

In attendance were the following: Chair Don Beard, Vice Chair Kevin Smith, Mary Ann Black, Fred Tabor, Megan Brown, Pat Mullins, Brad Perkins, Dave Wiggin, and Dr. Travis Titlow. Visitors included Ronny Stallings, President Gregg Reisinger, and Cheryl Newman. Staff present were Billy Smith and Laura Jesberg. The committee discussed a variety of topics that resulted in four motions. First, they suggested creating an appendix registry open to horses that comprised the foundation of Paint Horses—Quarter Horses and Thoroughbreds—limited to geldings and spayed mares. The appendix horses would have the same rights and privileges as solid Paint-breds.

Next, they suggested creating a complete animal welfare statement in concert with American Horse Council policies, including an action plan to reduce and/or eliminate undesirable genetic conditions, such as HYPP and HERDA, in time to include in the 2014 *Rule Book*.

The committee was in favor of a task force designated to develop a repatriation plan, which will include the participation-licensing program; a presentation on the task force's findings will be presented at the 2014 Convention. They also suggested APHA immediately remove the Youth World Show qualification requirement, beginning with the 2014 show; however, they did not see the need to modify qualification requirements for the Open & Amateur World Show. Furthermore, members also identified short- and long-term goals for the committee.

Membership Services Committee

Committee members attending the meeting were: Chair Jackie Mellon, Vice Chair Paula Mullins, John Corbin, Bob Drake, Colleen Dubsky, Gwen Melshaw, Cheryl Newman and EC liaison Scot Jackson. Staff Bruce Anderson, Cristin Conner, Kalyn Sanders and Laura Jesberg also attended. The group opened with discussion about the performance of the 50th anniversary membership promotion that kicked off on October 1, 2012, and ran through April 30, 2013. The promotion significantly slowed the decline in memberships, especially toward the end of the promotion in March, which also coincided with the start of a new telemarketing campaign to bring back lapsed members. The group strongly agreed that telemarketing needs to continue in an effort to not only generate revenue but also to keep the membership number above 50,000.

Discussions moved to the next membership promotion, which kicked off June 1. This promotion is similar to the 50th anniversary offering without the 50th anniversary theme. The committee was asked to generate ideas about the next item that could be offered as a membership premium, and several were suggested.

The topic of sponsors and revenue-sharing partnerships was initiated and the group reviewed the current sponsor list, which led to the topic of the new APHA Xtras program. The group strongly agreed this program could work very well.

Discussions turned to membership retention by state—12 states were identified as having the most significant losses. A task force will be assembled to research the cause for decline in each of these states.

Ombudsman Committee

Attending the meeting were: Chair Mike Short, Mary Anne Black, Cheryl Newman, Paula Mullins and John Corbin. The committee had previously been provided with two documents that had been developed to outline the purpose of the committee and the policies and procedures to be used in committee activity. The documents were accepted as presented. It was felt that it was vital for this committee to be discreet, confidential and neutral. Suggestions were made regarding methods of maintaining secure records. Further discussion was held regarding when and how the committee would get involved in situations and potential issues that might arise.

The committee determined that frequent communication would be key to the success of the committee, and it was determined that they would meet by conference call once a month. Other methods of communication will also be explored including a secure Drop Box.

Professional Horsemen's Committee

Members of the committee attending the meeting were: Chair Gerald Butler, Vice Chair Jan Larsen, Jerm Christensen, Matthew Henderson, Maryellen James, Diane Paris, Ronny Stallings, Ken Ware, Heather Young and EC liaison Ron Shelly. Staff Steven Imhof and visitors Kelly Christensen and Carl Thurow were also present. The first item of business was distribution of the newly created Policies and Procedures Manual, which will serve as an informational tool for potential applicants to understand more about the program, what it takes to become a member and expectations. Staff will produce the finished product and forward to the committee for final approval. Marketing opportunities were discussed, including direct email advertising to target audiences. Professional Horsemen shirts with the official logo are now available for purchase.

The committee then discussed screening and vetting of new applicants. A Code of Conduct was reviewed and approved as a guideline for the screening committee. The number of approved Professional Horsemen stands at 79, with six new applications pending. The program has received \$6,250 from application fees.

The committee discussed several topics at the request of the Executive Committee. They are in favor of removing the Youth qualifying requirement for the World Show and continuing the Open/Amateur qualifying requirement on a point-based system; in favor of adding Green classes to the World Show; recommend further exploration of participation-licensing; and against a cap on Breeders' Trust points.

Racing Committee

Members of the committee in attendance were: Chair Pancho Villarreal, Vice Chair Steve Wright, Sandra Garnett, Mike Richie, Rance Savage, and EC liaison Craig Wood, Staff Karen Utecht and guest Edie Savage were also present. The Racing Committee discussed the two rule change proposals: one revising registration requirements for stakes race eligibility of Solid Paint-Bred horses, and one outlining award-earning guidelines for horses who advance from the Solid Paint-Bred Registry to the Regular Registry during the year.

The 2014 graded stakes were reviewed and approved with no changes. The Masterpiece Challenge program was discussed. Efforts will continue regarding sponsorships and ways to continue growing this program.

The Paint Barrel Racing Incentive Program was discussed, and the first PBRIP event took place June 1. New events will be added to the PBRIP calendar soon. Information can be found on the Paint racing website under the "Barrel Racers" section.

The legislative session in Texas has once again closed without passing the gaming bill. Several different bills were proposed but did not have enough momentum to move up. The next legislative session is in 2015.

Montana racing is slowly being revived with several short race meets being offered. Idaho and Wyoming are also seeing an increased interest in racing. The Harvest Cup Futurity and Maturity at Les Bois Park in Idaho might help renew and increase the Paint racing interest in this area.

Recreational Riding Committee

In attendance were the following: Chair Anita Hertner, Vice Chair Carl Thurow, Lori Nevin, Sharon Karp, Nancy Olson, Rod Blackburn and Jerry Cable. Three visitors, attended: Judy Campbell, Gail Morris and Marilyn Novat, with EC liaison Mary Parrott and staff Cindy Grier. The committee discussed ideas to encourage regional clubs to host APHA-approved trail rides. Clubs might benefit from using special interests, such as St. Jude's and scholarships, as a way to encourage participation and attract new members. Clubs could also incorporate silent auctions and trail challenges to increase interest and club revenue.

The committee discussed the development of an All-Around Trail Horse award. Determining how and where the recognition could be awarded is challenging, but the committee suggested a nomination program that would include letters of recommendation, participation in Ride America, riding at an APHA-approved trail ride and volunteer hours. It was also suggested that the annual winner could be determined at the World Show or at the Fort Robinson trail ride.

The participation-licensing program was considered as a way of attracting new riders to Ride America. If approved, this option would allow riders of unregistered Paint stock horses to participate in APHA events, including Ride America.

The committee was then updated on changes to the Ride America program. Suggestions were made for priorities including development of a website for services of interest to recreational riders, including Ride America enrollment, logging and submitting hours, overnight stabling, mapping and tracking applications, and communication links.

Regional Club Committee

The meeting was attended by the following: Chair Lori Nevin, Vice Chair Butch Maxwell, David Lands, Robert Rasch, Clea Bobbitt, Ellen Coughlin, Gail Morris, Marjorie Lawler-Moser, and Kim Evans. Guests included Judy Campbell, Roxann Rohrl and Melissa Jayo; staff Julie Haney was also present. After reviewing action items and accomplishments, the committee formed a task force to review the regional club five-year review checklist currently in place. This will make the process more efficient and recommended collecting other key indicators.

The committee recommended APHA host educational classes at its annual Convention and potentially at the Zone level for club officers and show management in order to help strengthen clubs, bring additional attendance and help clubs to follow best practices.

Gist announced a new affiliate awards program. Directors and regional club officers will receive details via email, and it will also be posted on the regional club website. Members are encouraged to take advantage of the quality awards and discount programs.

The committee next discussed World Show qualifying, time frame for Youth World Show qualifying and the potential for Green classes at the World Show. They recommended eliminating Youth qualifying as a whole and to not include Green horse classes at the World Show. Next discussed was the Breeders' Trust program, and the committee generated two recommendations: cap the points and raise the private treaty fee, or charge the stallion subscription fee or per mare bred fee, whichever is greater.

The committee discussed rule change proposals and how to encourage some of its fundraising efforts to the APHF. Lastly, the Regional Club Sponsorship Program was discussed. A task force was appointed to review the

lower level of participation this year. The committee wants to ensure future disbursement of funds equitably and to perhaps offer the funds beyond to other regional club and zone events.

Rules Committee

Present were Chair Jean Fell, Vice Chair Nancy Westerlage, Lysane Cree, Drew Emmett, Karen Kennedy, Lisa Maxwell, Anne Rosen, Linda Vance, Jo Waldner, Butch Wonderlich, EC liaison Mary Parrott and visitor Dave Wiggin. Staff Jan Anderson and Cindy Grier also attended. Two rule change proposals were defeated by committee members. After discussion, the Committee was in agreement that the Regional Club Committee should become more involved in the new club approval process and in the five-year reviews of clubs to ensure compliance.

A clarification was approved to YP-110.D. to add Zone awards. At the request of the Executive Committee, discussions included Youth World Show qualification, Green classes and the Breeders' Trust program. No consensus was reached about the Breeders' Trust program, and members were asked to share their input with the Executive Committee.

Billy Smith joined the meeting and shared the purpose of the Judges Standards Task Force. Individual committees will have the opportunity to review the work of the task force.

Youth Coordinator Shelly deBarbanson came into the meeting and explained that the Amateur and Youth Committees wanted to send a new rule to the floor, and the emergency change process was explained.

Anne Rosen submitted a proposed reorganization of the disciplinary rules. After the originator reviews her suggestions, the Rules Committee will examine a final copy at Convention.

Other rule clarifications and procedures were reviewed and approved as requested by various committees or staff. Some clarifications might be ruled as immediate by the Rules Committee, while others would take effect when the rule changes are implemented at its discretion or upon request by the originator.

Ways & Means Committee

Attending the meeting were: Chair Linda Gordon, Diane Alves, Grace Harris, Diane Paris, Roxann Rohrl and EC liaison Scot Jackson. Staff present were Bruce Anderson and Rosemary Teate. The financial presentation to be given to the Board of Directors was presented and discussed. The group also discussed the many positive opportunities that present themselves at the upcoming combined AjPHA Youth World Show and Appaloosa National Show.

The committee discussed four topics at the request of the Executive Committee. They are highly in favor of making it easier for Youth to qualify for the World Show by reducing the number of shows and/or judges needed to qualify. The group also recommended Green classes take place at the World Show.

To help improve the Breeders' Trust, they recommend capping points earned or using a tiered or sliding scale on points earned. They also recommend a study be done to determine if it would be advantageous to base the stallion subscription fee off of the numbers of mares bred on a stallion's breeding report versus the advertised breeding fee.

In regard to the participation-licensing proposal, the group recommends further evaluation. Perhaps these horses could be advanced in the registry if they achieved a performance record and undergo DNA testing with parentage listed as unknown on these horses.

Youth

Attending the meeting were the following: Chair Sue Woodson, Karen Banister, Rhonda Culp, Robert McCulley, Jodie Moore Allyson Purcell and Amanda Ready. Youth Director Shelly deBarbanson was also present and discussed Youth and Novice Youth membership numbers with the committee. The group discussed the overall decline in the membership numbers, the lack numbers in the 13 & Under division, as well as the focus of the association on the value of membership. Other informational material about overall APHA membership numbers, 2012 show statistics, 2013 show statistics, the 2012 Youth World Show and highlights from the 2012 Open & Amateur World Show survey were handed out to the members.

The committee discussed several rule change proposals up for consideration. Regarding YP-015, the committee passed the rule change proposal to permit youth leasing in all zones, in addition to the original rule change proposal that would permit Youth leasing in international zones. They also passed a proposal to allow Novice Youth in international zones to show horses of any age in a snaffle bit. A proposal for YP-110 was passed with an amendment to add Youth Walk-Trot zone awards along with ROMs and Superiors. They also agreed to award ROMs in Limited Youth Working Cow Horse. A rule change proposal that would make Novice Youth Working Cow Horse a boxing-only class was also passed.

Several rule change proposals were considered regarding Novice Youth points and awards. The group agreed that Youth who receive remuneration for training or have solicited for training should not be eligible for Novice Youth cards, and unanimously passed YP-205, which would enforce this rule. They agreed Novice Youth points should count for awards, limited to the addition of Superiors and Zone awards, but not Honor Roll and Top 20 titles.

The Committee discussed the upcoming 2014 Youth World Games and ways to improve it, including more riding time and interaction with U.S. exhibitors. Several topics were discussed at the request of the Executive Committee. The group believes Green classes will be financially beneficial to the World Show and members, and that Youth World Show qualifying should be adjusted rather than eliminated. They also agreed to approve the creation of a judging rules task force.

American Paint Horse Foundation Committee

President Linda Gordon chaired the Board of Directors meeting. Attending were Gordon, , Jean Fell, Daranne Folino, Grace Harris, John Hertner, Jackie Mellon, Paula Mullins, Pat Mullins, Cheryl Newman and Renee Robinson. Visitors included Gail Morris, Sharon Karp, Nancy Olson, Butch Wonderlich and Kathy King. Staff Jan Anderson and Rosemary Teate were also present. Two scholarships were awarded to women who are seeking to further their training in therapeutic riding instruction. They also recommended giving a therapeutic scholarship to a Wounded Warrior if that party is seeking education in therapeutic riding. The Therapeutic Riding Sub-Committee suggested that a miniature horse or pig be sold or raffled to raise more funds. They also asked that APHF consider a recommendation to add a challenged riders' class to the World Show; the board approved a motion to make that recommendation to the Executive Committee.

The Scholarship Sub-Committee reported 39 renewals were granted contingent upon individuals meeting the GPA requirements, and seven new scholarships were awarded.

The Heritage Sub-Committee noted the proposal of displaying the Legacy of Color bronze at the Coors Art Show was not approved by that organization. Discussion ensued about other display opportunities for that piece of art.

The Hall of Fame Committee met and discussed nominations for the induction into the second class; selections

will be announced later in the year. Negotiations are ongoing for this year's award to the inductees. It was explained that future plans are being discussed about where to house the Hall of Fame and other artifacts relating to the heritage of APHA and Paint Horses.

The Find A Trainer program has declined in revenue earned this year thus far; members were asked to brainstorm ideas to rejuvenate it. Having been approved in a poll of board members, this year's Workshop fundraiser will support the purchase of a historical marker to honor the site of the first APHA organizational meeting.

Nominating Committee for Officers and Executive Committee

Chair Carl Thurow reported to the Board of Directors that the committee was recommending only one name for the position of Sixth Committee Member to be on the slate for the 2014 Convention, Mike Short, Director, Oklahoma. Other members of the nominating committee included: Pancho Villarreal, Sharon Bonner-Brown, Richard Cox, Kim Evans, Karen Kennedy, Renee Robinson, Karen Thomas, and Dr. Travis Titlow.

Appendices:

Appendix A – 2013 BOD Roll Call

Appendix B – Resume of EC Actions

Appendix C – Financials

Appendix D – Rule Change Proposals Forwarded for Convention Voting

2013
ROLL CALL

STATUS:

VOTING DIR 1
VOTING DIR 2
DIR AT LARGE 3
ALTERNATE 4
DIR@LAR (DSA) 5

13 Workshop PR	VOTING	DIRECTOR NAME	STATE AREA PROV #	STATUS
	0	Patterson, Glen	ON 1	2
	0	Muir, Jim	ON 1	5
	0	Tucker, Mike	ON 1	4
1	1	Cree, Lysane	NS 2	2
	0	TBA	NS 2	4
1	1	Coughlin, Ellen	NY 3	1
	0	Coughlin, Donald	NY 3	4
1	1	Roy, Karen	NH 4	2
	0	TBA	VT 4	4
1	1	Drake, Bob	MA 5	1
	0	Patti, Chuck	CT 5	4
	0	Miernicki, Nancy Gantz	PA 6	2
	0	Puhl, Donna	PA 6	1
1	1	Fick, Linda A	PA 6	4
1	1	Hayden, John	DE 7	1
	0	Hearn, Stephanie	DE 7	4
1	1	Umberger, Alison	VA 8	1
	0	Majewski, Joe	VA 8	5
	0	Kalan, Matthew	VA 8	4
1	1	Lawler-Moser, Marjorie	NJ 9	1
1	0	Moyer, Judy	NJ 9	4
1	1	Jones, Ann	GA 10	2
1	1	Westmorland, Lisa	GA 10	1
1	0	Swofford, Ike	GA 10	4
1	1	Thomas, Karen	NC 11	2
	0	Collins, Don	NC 11	1
1	1	Roberts-Brewer, Elizabeth	NC 11	4
1	1	Wall, Wayne	SC 12	1
	0	Miller, Anne Louise	SC 12	4
1	1	Burkhard, Craig	FL 13	2
1	1	Evans, Kim	FL 13	1
	0	Lewis, Linda	FL 13	1
	0	Simons, J. Jay	FL 13	3
	0	Simons, Nancy	FL 13	5
1	1	James, Mary Ellen	FL 13	4
1	1	Harrison, Jimmy	AL 14	2
	0	Wesley, Jeffery	AL 14	4
1	1	Blackburn, Rodney	KY 15	1
	0	Reinbolt, Paul	KY 15	3
1	1	Wood, Craig	KY 15	3
	0	TBA	KY 15	4
	0	Minor-Cothron, Jennifer	TN 16	1
	0	Shaw, Susan	TN 16	3
	0	Hill, Kathy D.	TN 16	4
1	1	Kennedy, Karen	AR 17	1
	0	Brady, Brian	AR 17	4
1	1	Ready, Amanda	MS 18	2
1	1	Ready, George	MS 18	3
	0	Headley, Mott	MS 18	3
	0	Walker, Guy	MS 18	3
	0	Beard, Pepper	MS 18	4
1	1	Westerlage, Nancy	LA 19	2
1	1	Woodson, Sue	LA 19	1
1	1	Parrott, Mary	LA 19	3
1	0	Ivins, Peggy	LA 19	4

2013
ROLL CALL

STATUS:

VOTING DIR 1
VOTING DIR 2
DIR AT LARGE 3
ALTERNATE 4
DIR@LAR (DSA) 5

13 Workshop PR	VOTING	DIRECTOR NAME	STATE AREA PROV #	STATUS
1	1	Emnett, Drew	OH 20	2
1	1	Johnson, Sue	OH 20	2
		Blay, Daniel	OH 20	1
1	1	Rohrl, Roxann	OH 20	5
1	1	Ternes, Marie	OH 20	4
1	1	Noder, Wendy	MI 21	2
1	1	Rasch, Robert	MI 21	2
	0	Loveland, Dennis	MI 21	1
	0	Schaub Jr., Mark	MI 21	4
	0	Kellerman, Brenda	IN 22	2
1	1	Cox-Dayhuff, Melanie	IN 22	1
1	1	Cox, Richard	IN 22	3
	0	Crull, Pauli	IN 22	5
1	1	Robinett, Robin	IN 22	4
1	1	Newman, Cheryl	IL 23	1
	0	Zimmerman, Brian	IL 23	1
	0	Newman, Pat	IL 23	3
	0	Wyrick, Jerry	IL 23	4
	0	Brunner, Barbara	WI 24	2
	0	McGinnis, Cindy	WI 24	1
	0	Majeskie, Vicki	WI 24	4
	0	Ruden, Monte	MN 25	2
1	1	Baker, Bruce	MN 25	1
	0	Arlander, Dr. Tom	MN 25	3
1	1	Himle, Merle	MN 25	4
1	1	Cable, Jerry	IA 26	2
	0	Roth, Cary	IA 26	1
1	1	Sheriff, Jennifer	IA 26	1
	0	Larson, Terrienne	IA 26	3
1	1	Reisinger, Gregg	IA 26	3
	0	Gulling, Carrie	IA 26	4
1	1	Maxwell, Butch	MO 27	2
1	1	Maxwell, Lisa	MO 27	2
	0	Parker, Olin	MO 27	1
	0	Neff, Duke	MO 27	5
	0	Stull, Martha	MO 27	5
1	1	Mullins, Paula	MO 27	4
	0	Stringer, Robert	ND 28	2
	0	TBA	ND 28	4
	0	Pugh, Diane	SD 29	2
1	1	Carey, I. J.	SD 29	5
1	1	Waldner, Jo	SD 29	5
1	1	Waldner, Richard	SD 29	5
1	1	Karp, Sharon	SD 29	4
1	1	Dubsky, Colleen	NE 30	2
1	1	Adam, Fred	NE 30	3
1	1	Hertner, Dr. John	NE 30	3
1	0	Siebenneicher, Wesley	NE 30	4
1	1	Lundquist, Stacie	KS 31	2
1	1	West, Casey	KS 31	1
	0	Hittle, Bill	KS 31	3
1	1	Thurrow, Carl	KS 31	3
	0	Hood, Kathy	KS 31	4
1	1	Butler, Gerald	OK 32	2
1	1	Perkins, Brad	OK 32	2

2013
ROLL CALL

STATUS:

VOTING DIR 1
VOTING DIR 2
DIR AT LARGE 3
ALTERNATE 4
DIR@LAR (DSA) 5

13 Workshop PR	VOTING	DIRECTOR NAME	STATE AREA PROV #	STATUS
	0	Hardcastle, Kevin	OK 32	1
1	1	Short, Mike	OK 32	1
	0	Robertson, Junior	OK 32	3
	0	Graves, Ray	OK 32	5
	0	Parsons, Pauline	OK 32	5
	0	Gralla, Todd	OK 32	4
1	1	Armstrong, Denise	TX 33	2
1	1	Gordon, Linda	TX 33	2
1	1	Robinson, Renee	TX 33	2
1	1	Sasser, Charlie	TX 33	2
1	1	Trebesch, Pat	TX 33	2
	0	Wilson, Cheri	TX 33	2
1	1	Gordon, Gary	TX 33	1
1	1	Mellon, Jackie	TX 33	1
	0	Price, Tina	TX 33	1
1	1	Sassar, Cathy	TX 33	1
1	1	Simons, Jana	TX 33	1
1	1	Smith, Kevin	TX 33	1
	0	Stiefel, Janice	TX 33	1
1	1	Tabor, Fred	TX 33	1
1	1	Villarreal, Franciso	TX 33	1
	0	Brashears, Bill	TX 33	3
	0	Calaway, Malcolm	TX 33	3
1	1	Jackson, Scot	TX 33	3
1	1	Paris, Diane	TX 33	3
1	1	Shelly, Ron	TX 33	3
	0	Shoemaker, Bud	TX 33	3
	0	Owings, Ernestine	TX 33	5
1	1	Wilson, Earnest	TX 33	5
	0	Griffin, Sally	TX 33	4
1	1	Snodgrass, Valera	TX 33	4
	0	Harke, Jackie	AB 34	2
	0	Botsford, Tammy	AB 34	1
	0	Fraser, Pete	AB 34	3
	0	Atchison, Lindsay	AB 34	4
	0	Johnson, Phil	SK 35	2
	0	TBA	SK 35	4
1	1	Morris, Gail	MT 36	2
	0	Baughn, Mary	MT 36	1
	0	Passage, Larry	MT 36	3
	0	TBA	MT 36	4
1	1	Beard, Don	WY 37	2
1	0	Beard, Vivian	WY 37	4
	0	Berbee, Tammy	CO 38	2
1	1	Rosen, Anne	CO 38	2
1	1	Banister, Karen	CO 38	1
1	1	Willard, Larry	CO 38	1
1	1	Corbin, John	CO 38	3
	0	Nelson, Forrest	CO 38	3
1	1	Fell, Jean	CO 38	5
	0	Gilbert, Peggy	CO 38	5
1	1	Manuello, Don	CO 38	5
	0	Fender, Seth	CO 38	4
	0	Morris, Ron	NM 39	1
1	1	Novat, Marilyn	NM 39	4

2013
ROLL CALL

STATUS:

VOTING DIR 1
VOTING DIR 2
DIR AT LARGE 3
ALTERNATE 4
DIR@LAR (DSA) 5

13 Workshop		DIRECTOR	STATE AREA	STATUS
PR	VOTING	NAME	PROV #	
1	1	Black, MaryAnne	ID 40	2
	0	Floyd, Ren	ID 40	1
1	1	Wonderlich, Butch	ID 40	3
1	1	Jayo, Melissa	ID 40	4
	0	Morgan, Sandi	UT 41	1
	0	Diamond, Richard	UT 41	3
	0	Parker, Carl	UT 41	3
1	1	Christensen, Bonnie	UT 41	4
1	1	Gilmore, Tom	AZ 42	1
	0	Sinclair, Trish	AZ 42	1
	0	Beals, Colin	AZ 42	3
	0	Elliott, Tom	AZ 42	3
	0	Buzzard, Jean	AZ 42	5
1	1	Kuhlwein, Mark	AZ 42	4
1	1	Moore, Jodie	BC 43	1
	0	Moore, Chris	BC 43	4
1	1	Nevin, Lori	WA 44	2
1	1	Odell, Shannon	WA 44	2
	0	Bearden, Joy	WA 44	1
1	1	Vance, Linda	WA 44	3
1	1	Harris, Grace	WA 44	5
	0	King, Kathy (Tuttle)	WA 44	4
1	1	Henderson, Matt	OR 45	2
	0	Chastain, Tamara	OR 45	1
	0	Simmelink-Rask, Michele	OR 45	1
	0	Wogman, Dr. Larry	OR 45	3
1	1	Suratt, Annie	OR 45	4
	0	Harned, Marissa	NV 46	1
	0	Winder, Karen	NV 46	4
1	1	Alves, Diane	CA 47	2
1	1	Bonner-Brown, Sharon	CA 47	2
1	1	Larsen, Jan	CA 47	2
1	1	Mannion, Jan	CA 47	2
	0	Flores, Libby	CA 47	1
1	1	Melshaw, Gwen	CA 47	1
1	1	Nash, Steve	CA 47	1
1	1	Titlow, Lynn	CA 47	1
1	1	Titlow, Dr. Travis	CA 47	3
	0	Williams, Lindy	CA 47	4
	0	Weight-Carter, Cindy	CA 47	4
	0	Rojas, Manuel	MX 48	2
	0	Zorrilla, Jorge	MX 48	4
	0	Garcia, Chico	BZ 49	2
	0	TBA	BZ 49	4
1	1	Hall, Lee Ann	AU 50	1
	0	Maxwell, Susan	AU 50	4
	0	Hagen, Monika	WG 51	2
	0	Leckebusch, Petra	WG 51	1
	0	Schmidt, Karl-Heinz	WG 51	1
	0	Oelke, Hardy	WG 51	5
	0	Huebner, Dirk	WG 51	4
	0	LaFlaquiere, Philippe	FR 52	2
	0	Pozzoli, Silvia	IT 52	2
	0	Rodeghiero, Alberto	IT 52	1
	0	LeJour, Francois	FR 52	4

2013
ROLL CALL

STATUS:

VOTING DIR 1
VOTING DIR 2
DIR AT LARGE 3
ALTERNATE 4
DIR@LAR (DSA) 5

13 Workshop PR VOTING	DIRECTOR NAME	STATE AREA PROV #	STATUS
0	Cox, Stephen	IR 53	1
0	TBA	IR 53	4
0	Painter, Sue	UK 54	1
0	Painter, Rob	UK 54	4
0	Verhulst-Paap, Nicole	TH 55	2
0	Eikelhof, Esther	TH 55	4
0	TBA	SW 56	2
0	TBA	SW 56	4
0	Schultz, Laura	DN 57	1
0	Bejerrum, Christina	DN 57	4
0	Brave, Mia	SN 58	2
0	Muller-Hansen, Annika	SN 58	4
0	Vorraber, Franz	AA 59	1
0	TBA	AA 59	4

110 TOTAL DIRECTORS, ALTERNATES & PAST PRESIDENTS IN ATTENDANCE

Total Directors	
DIRECTORS	117
DIRECTORS - AT - LARGE	36
DIR @ LAR (DSA)	20
Total Eligible to Vote	<u>173</u>
ALTERNATES	61
GRAND TOTAL	<u><u>234</u></u>

Voting Tally Present	
DIRECTORS	67
ALTERNATES	14
DIRECTORS - AT - LARGE	15
DIR @ LAR (DSA)&Tenure	8
TOTAL	<u><u>104</u></u>

Total Present	
DIRECTORS	67
ALTERNATES	20
DIRECTORS - AT - LARGE	15
DIR @ LAR (DSA)	8
TOTAL	<u><u>110</u></u>

Resume of Executive Committee Actions

American Paint Horse Association • October, 2012 – April, 2013

Executive Committee Meeting October 3-4, 2012 Fort Worth, Texas

Members of the Committee approved a \$68,000 addition to the 2012 Capital Expenditures budget (AC unit and accounting software additions.)

The Executive Committee approved a change to PAC Rule PR-000, adding APHA Approved Regional Clubs, American Competitive Trail Horse Association and American Stock Horse Association on the list of pre-approved organizations.

The Committee also approved a change to PAC Rule PR-060, moving the Trail Challenge and Competitive Trail events from the Endurance category to the Trail category with "1 bonus credit" given to trail events under 12 miles.

Executive Committee members approved a variance request to Rule RG-125. B. (parentage verification – horses 10 years old or older at time of registration), *2012 APHA Official Rule Book*, to allow the registration of the 1998 mare out of Butchers Ruby Reed #70,990 (WO#1205-0636), owned by Taylor M. Swanson, Toledo, Washington, without completed parentage verification.

Members of the Executive Committee approved a variance request to Rule RG-125. B. (parentage verification—horses 10 years old or older at time of registration), *2012 APHA Official Rule Book*, to allow the registration of the 2001 mare out of Pats Zip Anny #294,929 (WO#1207-1022), owned by Barbara Uhl, West Haven, Utah, without complete parentage verification.

The above two actions were amended to read that they are contingent on an attempt to contact the original owner contact the original owner to see if they would at least describe the foal (in lieu of photographs). If their description matches, then registration of the foal may proceed. If it doesn't, then staff will offer mitochondrial DNA as an alternative to get the foal registered.

Committee members approved a variance request to Rule GR-070. K. 4. (Breeding on suspension), *2012 APHA Official Rule Book*, to register a 2011 mare out of Dominant N Sassy #669,141, owned by Brenda Shipton, Marshville, North Carolina, despite the prior suspension of the owner at time of breeding.

The Executive Committee granted a variance request to Rule RG-070 (color rule/status change), *2012 APHA Official Rule Book*, to allow a status change for Get A Coo

#828,915, owned by Linsey O'Donnell, Spanaway, Washington to the Regular Registry.

The Committee granted a variance request to Rule SC-105. B. 1. C. (POR exceptions), *2012 APHA Official Rule Book*, for the Michigan PHC to hold a 2-judge show on May 25, 2013, and begin a POR on the following day.

Executive Committee members denied a variance request for a third POR for the Delmarva PHC on May 4-5, 2013.

Executive Committee Meeting Saturday, October 6, 2012 Fort Worth, Texas

The Executive Committee approved a resolution to allow Billy Smith, Executive Director, Lex Smurthwaite, Senior Director of Member Care, and Rosemary Teate, Senior Director of Accounting, to sign and transact business on behalf of the corporation.

The Committee agreed to allow Cheri Wilson, director, Texas, to continue to serve despite missing the convention roll call for the Board of Directors meeting, due to extenuating circumstances (knee surgery).

Members of the Committee tabled a motion to split the tobiano and overo color class results on the published Honor Roll listings.

Committee members approved the APHF board recommendations to reappoint Preston Shaw and Grace Harris and to appoint Daranne Folino and Renee Robinson to the APHF board.

Executive Committee Meeting Will Rogers Memorial Center November 13, 2012

The Executive Committee approved the 2013 Operating Budget as circulated.

Executive Committee members approved the Level I expenditures notated in the 2013 Capital Expenditures Budget as circulated, with one amendment (minus the membership profile research study, pg. IV, already expended.)

Members of the Executive Committee adopted a fee schedule for the registration of cropouts under new rule passed that corresponds to non-member fee schedule. (Non-member rates were doubled.)

Committee members approved a Breeders' Trust payout schedule to be rounded down on points due to the implementation of the half-point rule in 2013. (Example: payment would

be made for 10.5 points by rounding down to 10 and payment would be made on that basis.)

The Committee agreed to reconsider Motion #10 from the Oct. 3-4, 2012 meeting (**Motion #10: Travis Titlow moved and Susan Shaw seconded to approve a third POR for the Delmarva PHC on May 4-5, 2013. Motion defeated.**) and to approve a third POR for the Delmarva PHC on May 4-5, 2013; the Illinois PHA on June 1-2, 2013; the Empire State PHC on May 25-26, 2013; and the Garden State PHC on July 6-7, 2013, in variance to Rule SC-105. B. 2. b. 1. (number of PORs), *2012 APHA Official Rule Book*. Staff was also directed to write a proposed rule change regarding the number of PORs in the future.

The Committee members denied a variance request to Rule SC-105. B. 2. a. (show format and number of judges), *2012 APHA Official Rule Book*, from Jana Simons, Texas, on behalf of March to the Arch in St. Louis, MO on March 7-10, 2013, with regard to the proposed show format.

Members of the Committee agreed to allow the Executive Director the latitude to reduce the World Show qualification number of shows from four shows to two shows for cattle and speed events, jumping, driving, and/or other classes as he determines will be beneficial to World Show participation.

Executive Committee Conference Call December 4, 2012

Members of the Executive Committee approved the staff recommendations for modification of the Breeders' Trust Select Sale conditions for the 2013 sale as follow: (\$500 consignment fee (already in place), 8% Commission of selling price with a minimum of \$150 (\$150 minimum portion is new); *the same commission to apply to repurchases or horses offered with unmet reserve bids; \$800 stakes fee (with 100% going into the purse in 2014); 10% holdback after the sale costs are paid, with any remainder being added to the purse.* Motion passed.

The Executive Committee voted to approve Breeders' Trust amendments as recommended by staff. The amendments are as follows:

- Raise the Weanling nomination fee to \$125.
- Offer a discounted rate of \$100 if the foal is registered and nominated online concurrently.
- Allow stallion subscriptions after December 31 of the breeding year at the rate of 2.5 times the stud fee.
- If a stallion is purchased between February 1 and June 30 (see exclusions below), the

stallion can be subscribed without a late fee if the stallion subscription is postmarked within 30 days of the date of purchase (based on the date of sale on the transfer). The completed and signed transfer, original certificate, stallion subscription requirements and proper fees must be submitted.

- Exclusions: Include transferring from single name to joint name; a joint name to a single name; from one member of the same household to another; or from or to an entity owned in part or in whole by the previous owner.

Executive Committee members approved a \$15 increase in all registration application fees (unless application received online.)

The Committee also approved a new Special Handling Fee for non-electronic show results' submission as recommended by staff. Rules concerning the submission of show results are to be modified accordingly.

Committee members granted a variance request to allow an additional two-judge, one-day show for the March to the Arch Charity Paint Horse show on February 22-24, 2013.

Executive Committee Conference Call December 10, 2012

Members of the Committee reviewed and reiterated that they already approved three, two-judge, one-day shows (2+2+2) for the February 22-24, 2013 dates as submitted in the request for approval letter for the March to the Arch Charity Paint Horse Show. However, on the March 8-10, 2013 dates now being requested by the group, only two, two-judge, one-day shows are hereby approved. If a different format is desired that falls within the rules without a variance, the show management may proceed; i.e. a specialty event could be held (or up to two specialty events) following the two, two-judge, one-day shows currently now approved, pending application for such an event.

Executive Committee Meeting January 18, 2013 APHA Headquarters

Executive Committee members agreed to accept the recommendations of the Investment Committee and move forward as proposed with APHA's investments.

The Committee members approved a status change for Shes Legit #1,020,103, owned by Cross Creek Farm, Flemingsburg, KY, to the Regular Registry based on prior precedent.

Members of the Executive Committee accepted a modification proposal to the qualifying events recommended. A change of

requirements was presented that horses being shown in the designated specialty disciplines listed below (Regular Registry and Solid Paint Bred) must compete in two different APHA-approved show events, with a minimum of four judges total during the qualifying period. Horses may be shown in any state, regardless of residence, to qualify. Cutting, Working Cow Horse, Ranch Sorting, Roping, Goat Tying, Speed Events and Over Fences (except Hunter Hack) are the specified events.

Horses Being shown in the following classes only are not required to qualify due to time restraints and age of horse: Weanling Halter, Yearling Halter, Broodmares (must meet broodmare eligibility as outlined in Rule SC-175. L.f.), Yearling Longe Line and Yearling In-Hand Trail, Two-Year-Old performance horses, Three-Year-Old performance horses

Executive Committee members denied a variance for the Nebraska PHC to hold a 3rd and 4th Paint-O-Rama in 2013.

The Executive Committee agreed to allow the Nebraska PHC to hold a 3rd POR; they can have two, 2-judge shows back-to-back or one 4-judge POR.

Committee members also agreed to allow the Virginia and Carolina PHCs to hold a double show outside their boundaries with points to count toward Zone 7 for those four judges.

Executive Committee Meeting March 8-9, 2013 APHA Headquarters

The Executive Committee approved the proposed plan to hold a USTRC-managed Team Roping event during the 2013 Open/ Amateur World Championship Show in November. Also approved was the proposed APHA Paint Barrel Racing Incentive Program.

The Committee approved a dual-approval process for barrel racing, pole bending and reining events to increase ability for Paint Horses to qualify more easily for the World Championship Show.

Executive Committee members approved the concept of a Ranch Sorting National Championship, with RSNC sanctioned events serving as APHA World Show qualifying events for APHA contestants. RSNC will be responsible for tracking and reporting to APHA participation and dollars won on APHA horses. APHA will sponsor the RSNC and RSNC will sponsor the Ranch Sorting Division at the APHA World Championship Show, both groups to donate \$5,000 respectively to the other group.

Members of the Committee tabled eight rule change proposals, Controls AIX, GR-065, RG-020-3, RG-020-4, SC-160-1, SC-160-2, SC-165, and SC-190.

Committee members approved the variance request from the Oklahoma PHC to allow zone points to count for each club.

Members of the Executive Committee approved a change to the Breeders' Trust to require a \$100 fee every other year after six years of age for all nominated Breeders' Trust horses, with the owners receiving an invoice. (This was not ratified by BOD-see minutes.)

The Executive Committee approved an application for club affiliation from the Belgium PHC.

The Committee also approved the club affiliation request from the Snake River PHC in Idaho.

Committee members voted to suspend the charters of the Idaho PHC and the Treasure Valley PHC, as recommended by staff, until such time as the clubs can submit a formalized plan to reorganize.

Members of the Executive Committee approved the Westin Hotel as the convention hotel for 2014.

The Executive Committee agreed to increase the non-member, non-club or zone, show application fee to \$70; dual-approved show fees would remain the same.

Executive Committee members approved the changes made to the Ride America program, i.e. to charge an annual maintenance fee of \$10 and to grandfather participants who have logged hours in the last 24 months.

Members of the Committee approved the clarifications to allow other individuals and entities the opportunity to host an APHA-approved trail ride and changes to the regional club guidelines listed in the rule book.

Executive Committee members approved the clarifications to the Ride America program to require all logs to be submitted by Jan. 10 for the previous award year to be eligible for the annual Saddle Star award.

The Executive Committee voted to approve the fee changes as proposed by staff for implementation in 2014.

Fee Schedule

All fees based on postmark (postal meters not accepted), U.S. Funds Only drawn on a U.S. bank or additional fees may apply Do not send cash. If you pay by check, your check may be converted into an electronic fund transfer.

Membership Fees

Annual Membership	\$40
3-Year Membership	\$90
5-Year Membership	\$150
AjPHA Membership	\$20
AjPHA 3-Year Membership	\$40
j-Term Membership	\$100
Lifetime Membership	\$500
Lifetime Replacement Card	\$5

Miscellaneous Fees	Members	Non-Members
Credit Card charge back or retrieval fee	\$35	n/a
E-mail with attachment / Fax	\$5	\$10
Each Additional Page	\$1	\$2

Registration Fees

Optional /Special Handling Fee(s):	Members	Non-Members
Rush per certificate	\$50	\$50
FedEx / USPS / DHL return	\$25	\$25

See Rule RG-050.D. for other requirements on rush work

Regular Registry (Paint Parent)	*Mbr Online	Members	Non-Members
Foaling date to 6 month birthdate	\$25	\$40	\$80
7 to 9 month birthdate	\$35	\$50	\$100
10 to 12 month birthdate	\$50	\$65	\$130
13 to 24 month birthdate	\$100	\$115	\$230
25 to 36 month birthdate	\$250	\$265	\$530
37 to 48 month birthdate	\$350	\$365	\$730
Past 48 month birthdate	\$500	\$515	\$1030

Crop-out (Product of QH/TB sires/dams or combination)

0-90 Days after foaling or June 30 of the calendar year foaled, whichever is later	\$70	\$85	\$170
July 1 through September 30 of the calendar year foaled	\$80	\$95	\$190
October 1 through December 31 of the calendar year foaled	\$95	\$110	\$220
Yearling Year	\$200	\$215	\$430
2-Year-Old Year	\$500	\$515	\$1030
3-Year-Old Year & Older	\$1000	\$1015	\$2030

Solid Paint-Bred/Breeding Stock

Foaling date to 6 month birthdate	\$15	\$30	\$75
7 to 9 month birthdate	\$25	\$40	\$85
10 to 12 month birthdate	\$30	\$45	\$90
13 to 24 month birthdate	\$50	\$65	\$110
25 to 36 month birthdate	\$60	\$75	\$120
37 to 48 month birthdate	\$100	\$115	\$160
Past 48 month birthdate	\$125	\$140	\$185

International Appendix

Foaling date to 24 month birthdate	\$25	\$40	\$85
25 to 48 month birthdate	\$45	\$60	\$105
Past 48 month birthdate	\$65	\$80	\$125
Ownership Update on certificate of registration	\$15	\$20	\$65

Certificate Fees (Duplicate, Corrected, Replacement)

Optional /Special Handling Fee(s):	Members	Non-Members
Rush per certificate	\$50	\$50
FedEx / USPS / DHL return	\$25	\$25
Corrected certificate	\$25	\$70
Duplicate certificate	\$25	\$70
Horse name change	\$100	\$200
Picture replacement certificate	\$25	\$70
Re-registration	\$50	\$100
Status change		
Foaling date to 12 month birthdate	\$50	\$95
13 to 24 month birthdate	\$90	\$135
25 to 36 month birthdate	\$100	\$145
37 to 48 month birthdate	\$140	\$185
Past 48 month birthdate	\$190	\$230

See Rule RG-050.D. for other requirements on rush work

Embryo Transfer Fees

	Members	Non-Members
Embryo transfer	\$100	\$200
Late embryo transfer (mares enrolled after implant date)	\$200	\$400

Mare Enrollment Fees

	*Mbr Online	Members	Non-Members
Mare enrollment - (AQHA or TB)	\$10	\$25	\$70
Ownership update	\$0	\$5	\$5

Misc. MemberCare Fees

	Members	Non-Members
Computer flagging	\$75	\$120
Inspection	\$100	\$250
Inspection -special (deposit for possible fraudulent markings when skin biopsies and hair samples are required)	\$200	\$450
Lease	\$15	\$60
Letter of Authorization	\$15	\$60
Multiple parentage analysis	\$250	\$500
Office processing	\$10	\$10
Pedigree	\$20	\$65
Reserve name (12 months-based on receipt of request)	\$100	\$100
Signature Authorization	\$10	\$55

Semen Permit Fees (cooled or frozen)

	Members	Non-Members
Semen permit – per stallion	\$100	\$200
Late fee – per stallion (additional)	\$100	\$200

Stallion Listing Fees

	*Mbr Online	Members	Non-Members
Stallion listing (APHA, AQHA or TB)	\$75	\$90	\$150
Ownership update (AQHA or TB)	\$0	\$5	\$5

Stallion Breeding Report Fees

	*Mbr Online	Members	Non-Members
Report filed (postmarked) – before or during the 7th month of the breeding year	\$5	\$10	\$55
Report filed (postmarked) – during or after the 8th month and before the 12th month of breeding year	\$10	\$20	\$65
Plus per mare on report (exposed)	\$5	\$5	\$10
Late filing –per stallion in addition to regular fee	\$25	\$25	\$70
Corrected stallion breeding report (per mare)		\$10	\$20

Transfer of Ownership Fees

Optional /Special Handling Fee(s):	Members	Non-Members
Rush per certificate	\$25	\$50
FedEx / USPS / DHL return	\$25	\$25
Transfer of ownership	\$15	\$60
Transfer by Indemnity	\$75	\$150
Transfer date correction	\$5	\$10
Transfer fee from joint ownership to single ownership in divorces	\$10	\$55
Stableman's Lien	\$50	\$100

Genetic Testing Fees

Optional /Special Handling Fee(s):	Members	Non-Members
Rush – hair kit(s) via email	\$25*	\$25*
FedEx / USPS / DHL hair kit(s) in addition to rush fee	\$25	\$25
DNA hair kit (per unregistered horse)	\$60	\$60
DNA hair kit for registered horse	\$70	\$70
DNA Replacement Kit	\$5	\$10
DNA multiple hair kits, 5-9 horses, per kit	\$55	\$55
DNA multiple hair kits, 10-14 horses, per kit	\$50	\$50
DNA multiple hair kits, 15 or more horses, per kit	\$45	\$45

Coat Color Testing-comprehensive coat color package –per horse (includes red factor, agouti, cream, champagne, gray, pearl, silver, OLWS, Sabino1 and Tobiano)	\$110	\$110
Individual coat color tests – per horse Red factor + Agouti	\$40	\$40
All other individual coat color tests – per test per horse (cream, champagne, gray, pearl, silver, OLWS, Sabino 1 and tobiano)	\$25	\$25
DNA Disease Diagnostic package –per horse (includes HERDA, HYPP, GBED and OLWS)	\$100	\$100
Individual disease diagnostic test – per test per horse	\$50	\$50

*For transactions online go to www.aphaonline.org



APHA Financial Results

Board of Directors

Workshop

June 2013

Results to be Reviewed



1. 2012 Financial Results
2. 2012 Revenue by Major Departments
3. Statement of Financial Position
4. 2012 Operating Results – Open & Amateur World Show & Gift Show
5. Comparison of Operating Results – Open & Amateur World Show & Gift Show – 2011 vs. 2012
6. 2012 APHA Farnam Breeders' Trust Select Sale Results
7. Operating Results – January/April 2013

Operating Results – 2012



	2012 FORECAST	2012 ACTUAL	2012 DIFFERENCE
Operating Revenue	\$ 7,527,396	\$ 7,536,048	\$ 8,652
Operating Expense	\$ 8,324,748*	\$ 8,683,039	\$ 358,291
Operating Results	\$ (797,352)	\$ (1,146,991)	\$ (349,639)

*After removing \$900,000 in payroll and related expenses.

Net Results - 2011 vs 2012



	2011	2012	DIFFERENCE
Operating Revenue	\$ 7,967,181	\$ 7,536,048	\$ (431,133)
Operating Expense	\$ 8,792,980	\$ 8,683,039	\$ (109,941)
Operating Results	\$ (825,799)	\$ (1,146,991)	\$ (321,192)
Investment Income	\$ (425,754)	\$ 757,669	\$ 1,183,423
Net Results	\$ (1,251,553)	\$ (389,322)	\$ 862,231



Registration Dept. Revenue

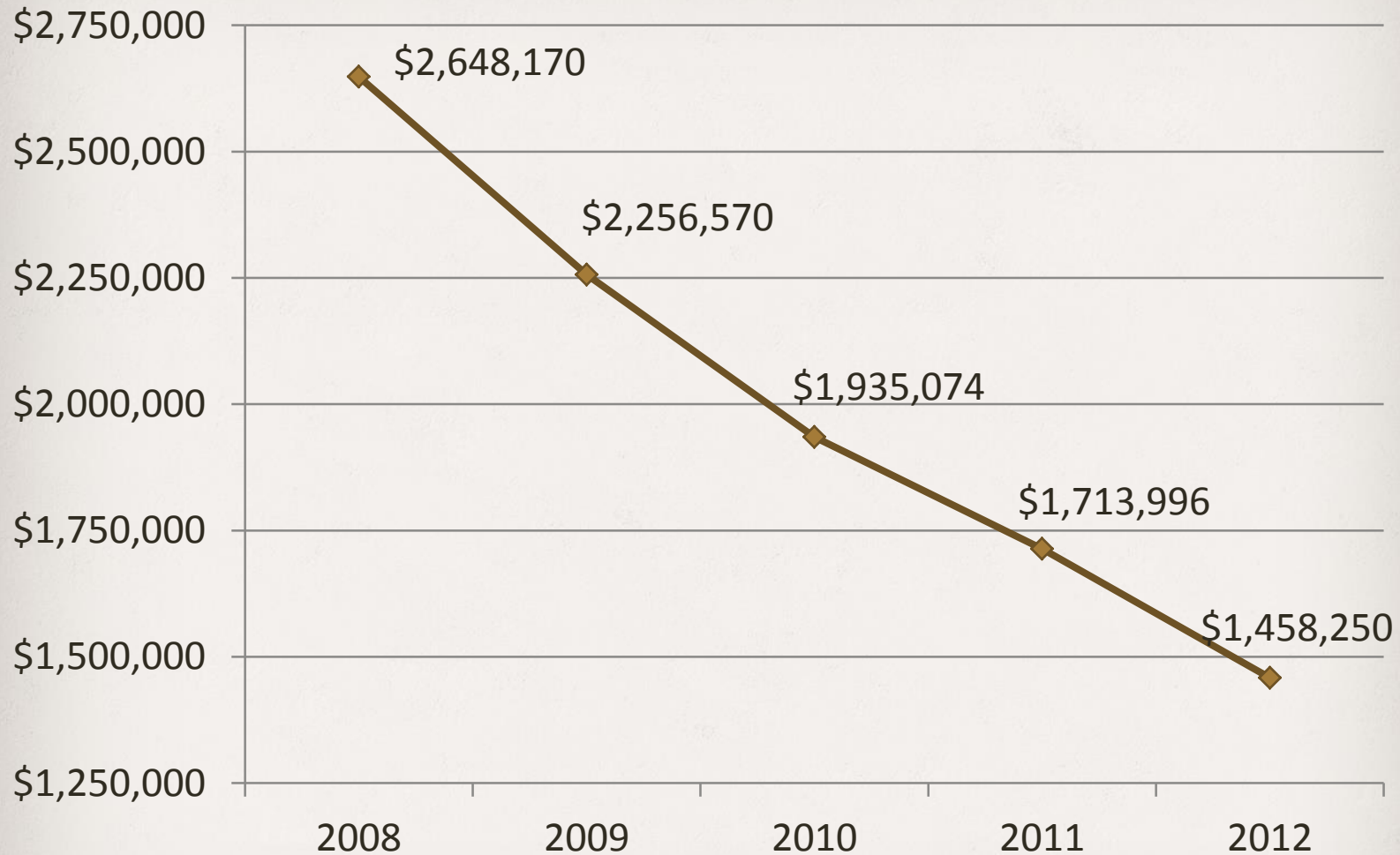



Member Service Revenue

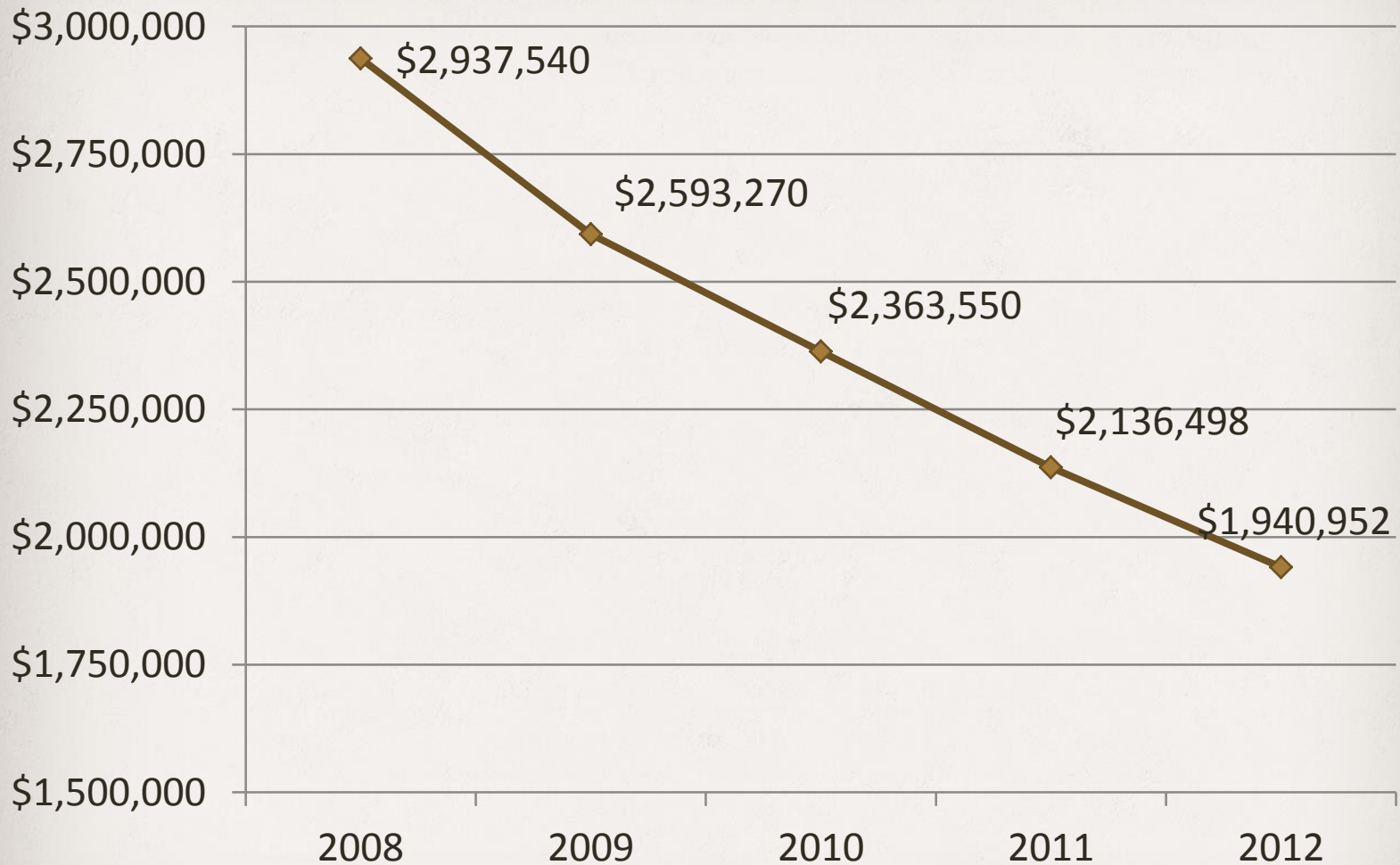



Publications Revenue





World & Gift Show Revenue

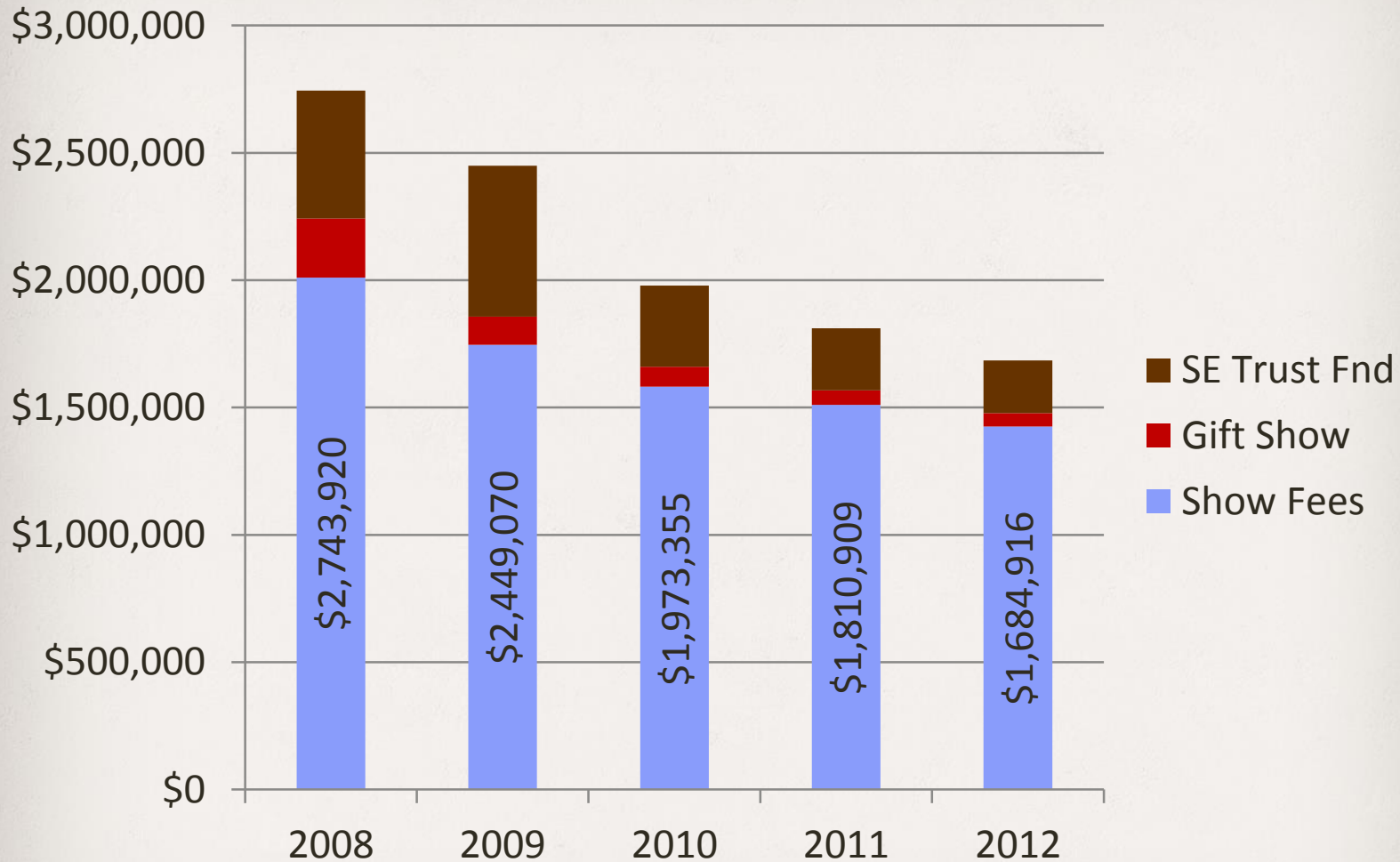



Performance Dept. Revenue

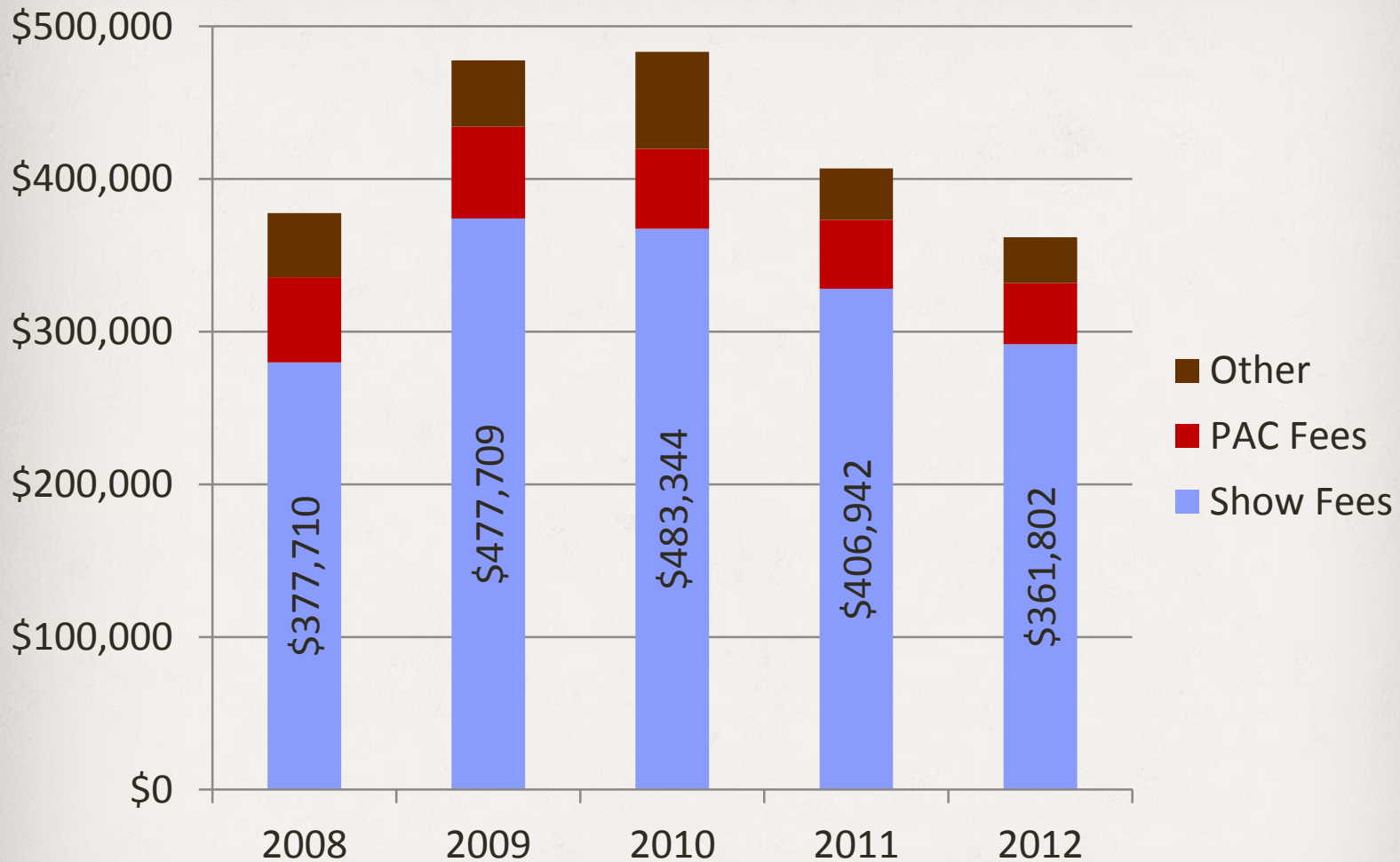



Sponsorship Revenue

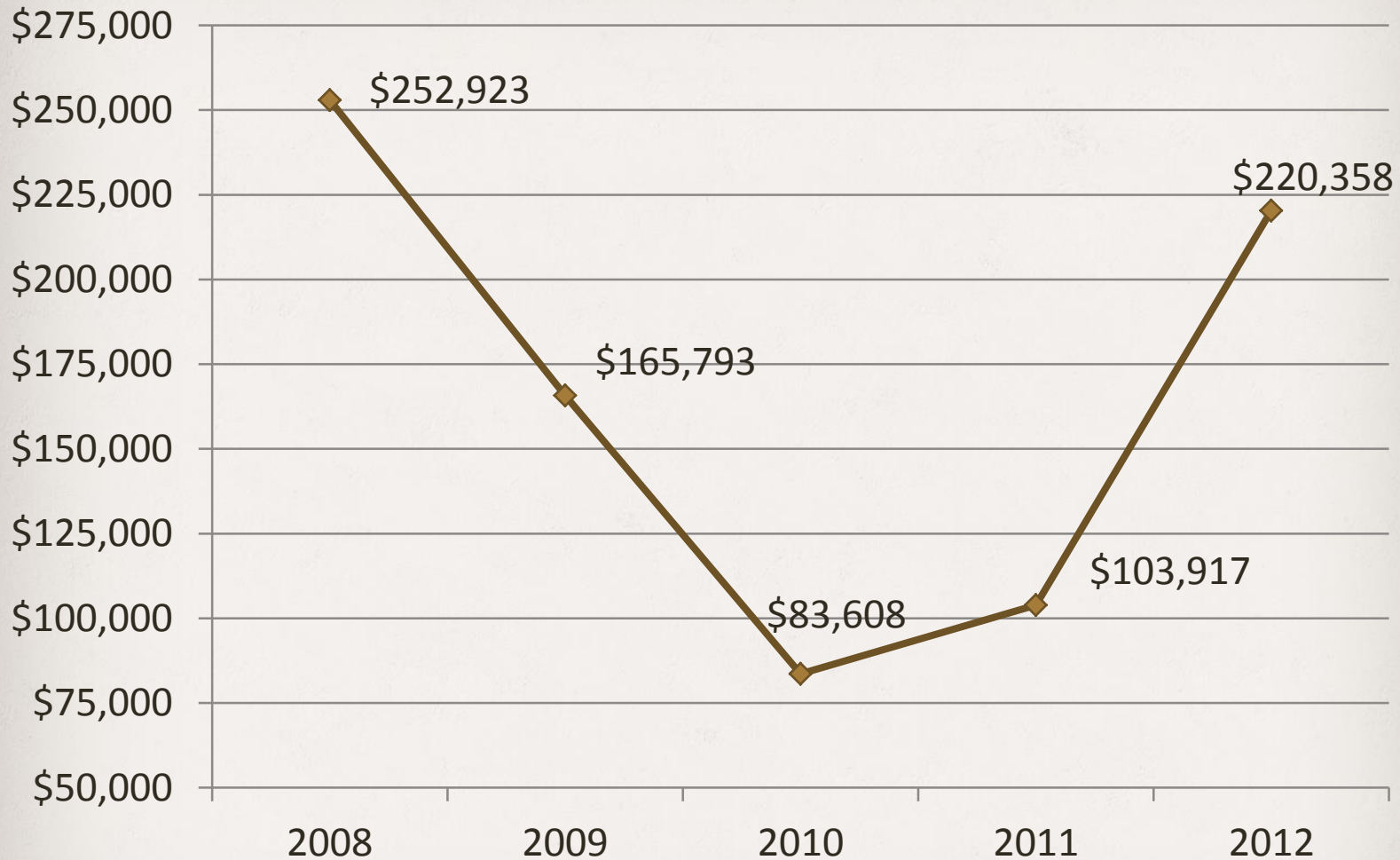



General Store Revenue



Statement of Financial Position



	December	December
ASSETS	2011	2012
Cash	\$ 917,485	\$ 1,294,726
Cash/restricted	\$ 294,469	\$ 223,527
Investments @ market	\$ 11,177,457	\$ 10,420,598
Investments @ mkt, rstrct	\$ 2,390,000	\$ 2,092,000
Accounts receivable	\$ 322,466	\$ 427,328
Accrued interest receivable	\$ 3,754	\$ 2,498
Accrued interest receivable, rstrct	\$ 5,229	\$ 4,237
Inventory	\$ 46,173	\$ 98,002
Prepaid expenses	\$ 70,976	\$ 57,796
Property & equipment, net	\$ 4,704,516	\$ 4,601,245
Total Net Assets	\$ 19,932,525	\$ 19,221,957

Statement of Financial Position



	December 2011	December 2012
<u>LIABILITIES AND NET ASSETS</u>		
Accounts payable-trade	\$ 383,089	\$ 493,053
Accrued expenses	\$ 1,198,217	\$ 1,101,457
Deferred revenues	\$ 2,737,646	\$ 2,695,532
Total Liabilities	\$ 4,318,952	\$ 4,290,042
<u>NET ASSETS</u>		
Temp restricted, B Trust	\$ 1,770,742	\$ 1,478,406
Unrestricted	\$ 13,842,831	\$ 13,453,509
Total Net Assets	\$ 15,613,573	\$ 14,931,915
Total Liabilities & Net Assets	\$ 19,932,525	\$ 19,221,957



Operating Results – OAWS & Gift Show

American Paint Horse Association

	OAWS	GIFT SHOW	COMBINED
Operating Revenue	\$ 1,075,137	\$ 30,691	\$ 1,105,828
Operating Expense	\$ 1,109,562	\$ 14,688	\$ 1,124,250
2012 Operating Results	\$ (34,425)	\$ 16,003	\$ (18,422)
Special Events Trust Fund Contribution	\$ 141,601	\$ 7,250	\$ 148,851
2012 Net Operating Results	\$ 107,176	\$ 23,253	\$ 130,429

Comparison of Operating Results OAWS & Gift Show – 2011 vs. 2012



	2011	2012	DIF 11 VS. 12
Operating Revenue	\$ 1,185,915	\$ 1,105,828	\$ (80,087)
Operating Expense	\$ 1,125,643	\$ 1,124,250	\$ (1,393)
Operating Results	\$ 60,272	\$ (18,422)	\$ (78,694)
Special Events Trust Fund Contribution	\$ 140,948	\$ 148,851	\$ 7,903
Net Operating Results	\$ 201,220	\$ 130,429	\$ (70,791)

Operating Results – YWS & OAWS & Gift Show

American Paint Horse Association



	YWS	OAWS	COMBINED
Operating Revenue	\$ 380,980	\$ 1,105,828	\$ 1,486,808
Operating Expense	\$ 498,729	\$ 1,124,250	\$ 1,622,979
2012 Operating Results	\$ (117,749)	\$ (18,422)	\$ (136,171)
Special Events Trust Fund Contribution	\$ 56,756	\$ 148,851	\$ 205,607
2012 Net Operating Results	\$ (60,993)	\$ 130,429	\$ 69,436

Comparison of Operating Results- YWS & OAWS & Gift Show – 2011 vs. 2012



	2011	2012	DIF 11 VS. 12
Operating Revenue	\$ 1,567,389	\$ 1,486,808	\$ (80,581)
Operating Expense	\$ 1,618,319	\$ 1,622,979	\$ 4,660
Operating Results	\$ (50,930)	\$ (136,171)	\$ (85,241)
Special Events Trust Fund Contribution	\$ 242,520	\$ 205,607	\$ (36,913)
Net Operating Results	\$ 191,590	\$ 69,436	\$ (122,154)

Comparison of Operating Results- APHA Farnam Breeders' Trust Select Sale 2011 vs. 2012

American Paint Horse Association



	2011	2012	DIF 11 VS. 12
Operating Revenue	\$ 27,849	\$ 61,178	\$ 33,329
Operating Expense	\$ 32,411	\$ 31,905	\$ (506)
Operating Results	\$ (4,562)	\$ 29,273	\$ 33,835
Special Events Trust Fund Contribution	\$ 1,000	\$ 1,500	\$ 500
Net Operating Results	\$ (3,562)	\$ 30,773	\$ 34,335

Operating Results – Jan/Apr 2013

American Paint Horse Association



	YTD BUDGET	YTD ACTUAL	YTD DIFFERENCE
Operating Revenue	\$ 2,117,758	\$ 2,062,454	\$ (55,304)
Operating Expense	\$ 2,860,343	\$ 2,391,279	\$ 469,064
Operating Results	\$ (742,585)	\$ (328,825)	\$ 413,760



Net Results – Jan/Apr 2012 vs 2013

American Paint Horse Association

OPERATING RESULTS - JANUARY/APRIL 2013

	YTD 2012	YTD 2013	YTD DIFFERENCE
Operating Revenue	\$ 1,903,818	\$ 2,062,454	\$ 158,636
Operating Expense	\$ 2,565,171	\$ 2,391,279	\$ (173,892)
Operating Results	\$ (661,353)	\$ (328,825)	\$ 332,528
Investment Income	\$ 506,534	\$ 268,197	\$ (238,337)
Net Results	\$ (154,819)	\$ (60,628)	\$ 94,191

Summary



- Cultural and organizational transformation is underway.
- Careful reductions in force.
- Making greater use of contract labor.
- Keeping sharp eye on spending.
- Actively seeking opportunities to grow existing revenue streams and develop new revenue streams.
- Investing to fully automate as many APHA transactions as possible.
- Making steps to further improve forecasting, budgeting and reporting.
- Becoming more and more aware of organizations having a negative impact on APHA revenue and competing more and more aggressively to protect and grow APHA revenue.
- We thank you for your continued support.

2013 Rule Change Proposals

The following rule change proposals were brought out of the standing committees at the recent APHA Workshop, held May 30-June 1, 2013, in Grapevine, Texas. These proposals will be presented at the 2014 APHA Convention, Feb. 21-24, 2014, for a vote by the directors to pass or defeat them. All of these proposals will take effect on January 1, 2015.

Exception: You will note some of the rule proposals have been forwarded to a task force. This task force is reviewing a number of changes to show and judging rules in addition to those so marked herein, which will then be reviewed by the General Show and Contest Committee, the Judges Committee and the Rules Committee; the changes that are approved by those three committees, will then be reviewed by the Executive Committee at its November meeting. If the rules are approved, the Board of Directors voted during Workshop to allow the Executive Committee to implement these particular changes on January 1, 2014.

A 2014 Rule Book will NOT be published; instead, all rules passed will appear on the website.

These proposed changes will be available on the APHA website at apha.com—click on Forms and Downloads/Rule Books.

Control SC-075

Rule SC-075., new D., move from GR-060.I, page 43 (2013 rulebook)

D. APHA **will** accept suspension rulings pertaining to cruel or inhumane treatment of horses from other recognized equine-related associations and state racing commissions; the effect of which is to automatically suspend the individual from APHA membership privileges for a length of time **at least** equal to the initial suspension period **by the other association.** (See list of recognized associations on the APHA web site at www.apha.com.)

Control SC-160

Rule SC-160., delete.

~~M. ANNOUNCING NAMES OF HORSES/OWNERS/EXHIBITORS.~~ Show

~~management shall not announce the names of horses, owners and/or exhibitors prior to judging being completed in a class. All entries should be referred to by exhibitor number.~~

Control SC-160-3

Rule SC-160., change and delete 3.

General Show Rules.

- A. **ELIGIBILITY TO SHOW.** A show must be open to all Paint Horse members in good standing with the APHA to gain approval. All exhibitors **and owners** must possess a current APHA/AjPHA membership in order to show in APHA-approved classes. No exhibitor **or owner** may be required to be a member of any organization other than APHA in order to compete in an approved class. Show management must inspect the current card, legible photocopy of the current card or a temporary card at each show. Application/renewal for an APHA or AjPHA membership card shall be made on a form provided by APHA, available from them at no charge, and returned with applicable fees as provided. A temporary membership card may be applied for through the show secretary at an APHA approved show. See Rules GR-020.H., AM-015.A. and YP-005.A.
1. Age. The minimum age of an exhibitor will be five (5) years of age with the exception of Leadline. For APHA purposes, the age of an individual on January 1 shall be maintained throughout the entire calendar year.
 2. A youth must be at least 16 years of age to exhibit a stallion in open classes. See Rule YP-080.B.1.

~~3. In order for a Paint horse to receive an APHA award, the owner must be an APHA or AjPHA member on the date the award is bestowed. To be eligible to receive the award, the owner may retroactively purchase the required annual membership. Despite owner eligibility, the horse's achievement will be recorded in its permanent record.~~

RELATED RULES:

GR-020., change to read. Membership.

H. ~~In order for a Paint horse to receive an APHA award, the owner must be an APHA or AjPHA member on the date the award is bestowed. To be eligible to receive the award, the owner may retroactively purchase the required annual membership. Despite owner eligibility, the horse's achievement will be recorded in its permanent record.~~ **All exhibitors and owners must possess a current APHA/AjPHA membership in order to show in APHA-approved classes.** See Rule SC-160.A., AM-015.A. and ~~YP-005.A.4.~~ **YP-005.A.5** regarding exhibitor and **owner** membership requirements.

AM-015., change to read. Amateur Card Application or Renewal.

A. **AMATEUR EXHIBITOR CARD.** Every exhibitor competing in an Amateur class must possess a current Amateur exhibitor card issued by the APHA, as well as a current APHA membership (see SC-160.A.). **All owners must also possess a current APHA membership in order to show in APHA-approved classes.** Show management must inspect the current card, legible photocopy of the current card, or a temporary card at each show.

Application/renewal for an Amateur card shall be made on a form provided by APHA, available from them at no charge, and returned with applicable fees as provided below. A temporary Amateur card (~~\$40~~) may be applied for through the show secretary at an APHA-approved show. A current APHA membership at the time of application is mandatory. See Rules GR-020.H., SC-160.A. and YP-005.A.4.

YP-005., change to read. Membership.

5. A current AjPHA membership will be mandatory to exhibit at an APHA-approved show (see SC-160.A.) Exception: Leadline or Walk-Trot classes. **All owners must also possess a current APHA/AjPHA membership in order to show in APHA-approved classes.** Show management must inspect the current card, legible photocopy of the current card, or a temporary card at each show. Application/renewal for an AjPHA membership card shall be made on a form provided by APHA, available from them at no charge, and returned with applicable fees as provided. A temporary membership card may be applied for through the show secretary at an APHA approved show. See Rules GR-020.H., SC-160.A. and AM-015.A.

PR-000., change to read. APHA PAINT ALTERNATIVE COMPETITION (PAC).

B. PAC ENROLLMENT

3. All PAC exhibitors **and owners** must be current APHA/AjPHA members at time of enrollment and to receive PAC credits.

~~4. In order for the horse to receive any awards or certificates, the owner of the~~

~~said horse must be a current member of the APHA.~~

Control SC-193 (with amendments)

Rule SC-193., new Rule to read. 2-Year-Old Longe Line

- A. Class is limited to 2 year olds. Points in this class will be applied toward an ROM. Points in this class will not count toward an APHA Championship or any other APHA awards.
- B. *If a two-year old horse is shown under saddle at any show where APHA approved classes are held, this horse is no longer eligible to be shown in two-year old longeline the remainder of that calendar year.*
- C. The purpose of showing a 2 year old on a longe line is to demonstrate that the horse has the movement, manners/expression/attitude, and conformation to become competitive under saddle. Therefore, the purpose of this class is to reward:
 - 1. Quality of movement
 - 2. Manners/Expression/Attitude
 - 3. Conformation suitable to future performance, and the horse should be judged with its suitability as a future performer under saddle in mind. This class should define what it means to be a "Western pleasure prospect" or "hunter under saddle prospect." Because these are yearlings, they are not expected to demonstrate the behavior or quality of a finished show horse, but only that performance necessary for a reasonable presentation to the judge.
- D. Equipment. Horses are to be shown in a halter. Either a regular or a show type halter is acceptable. For the longeing

- demonstration, the only attachment allowed to the halter is a longe line. The longe line may not exceed 30 feet with a snap attached to the halter. The longe line must hang free from the halter without touching any part of the horse. It is permissible to use a longe whip however, disqualification will occur if the exhibitor blatantly strikes the horse with the whip to cause forward or lateral movement at any time during the longeing demonstration. No other equipment is allowed on the horse during longeing demonstration portion of the class. Mechanical or retractable longe lines are not allowed. For the conformation inspection, a lead shank, such as used in halter or showmanship classes may be exchanged for the longe line prior to the longeing demonstration. Exhibitors are not to be penalized for using regular halters and plain longe lines, nor are they to be rewarded for using show halters and show longe lines. Only movement manners/expression/way of going, and conformation are being judged. The type of equipment used is not to be a consideration in placing the horse as long as the equipment meets the requirements stated above.
- E. Attire. Conventional Western attire is mandatory according to SC-235 except if a prospect is considered to be a Hunter prospect, the mane may be braided and conventional English attire is suggested according to SC-195. The type of attire worn by the exhibitor is not to be a consideration in placing the horse as long as the attire meets the requirements stated above.
 - F. Gaits to be judged according to APHA rules for gaits for Western pleasure

- (SC-241) and hunter under saddle (SC-201.A).
- G. The conformation inspection will occur as the horse is walked into the arena prior to the longing demonstration at which time the judge will also evaluate the horse for conformation suitable for future under saddle performance. The judges may not discriminate for or against muscling, but rather look for a total picture, emphasizing balance, structural correctness, and athletic capability. Each entry will be walked into the arena to the judge and pause for evaluation individually. They will then trot off straight and around a cone and take a place on the wall inside the arena. All entries will be inspected in this fashion and as the "trot-off" is administered, horses showing evidence of lameness should be excused from the class at that time.
- H. Judge(s) will be outside the longing circle. The exhibitor will enter the longing area and await the audible start signal. When the signal is given, the exhibitor will be allowed 11/2 minutes (90 seconds) to present the horse. At the end of 11/2 minutes, a signal will be given again to signify the end of the demonstration. Show management has the option of adding a "half-way" signal if they choose. (The signal may be a bell, whistle or announcement.)
1. Once the class has started, horses warming up prior to their go may only warm up at the walk.
- I. The horse will be scored at the walk, jog or long trot, and lope or canter in both directions. Any horse that does not exhibit these gaits in each direction will be disqualified from the class. Additionally, the judge shall immediately excuse any horse who exhibits obvious lameness at any time during the class. Exhibitors may begin work in the direction of their choice (counter or clockwise).
- J. At the end of the 11/2 minutes, a signal will be given and the exhibitor shall at the request of show management, retire from the longing area and retire to the far end of the ring. The horses are to stand quietly on the rail while the other exhibitors are being judged.
- K. The horses are judged on movement (*34 points*) according to APHA rules for gaits (SC-201.A. and SC-241). Manners/Expression/Attitude (*14 points*) and conformation suitable to purpose (*6 points*) and use of circle (*6 points*). Judges may not discriminate for or against bulk, but rather look for a total picture, emphasizing balance and athletic capability.
- L. If the horse plays on the longe line, it shall not count against the horse. The judge will, however, penalize the horse for excessive bucking or running off, stumbling or displaying attitudes that are uncomplimentary to pleasure horses. Falling down will constitute disqualification. Credit is to be given to the horse that, under light control and without intimidation, goes softly and quietly while performing the required gaits. The overall picture of a good mover is a horse that goes forward with comfort, confidence and willingness, a fluid stride with a full extension of the limbs, and a head and neck carriage that is naturally comfortable and compatible with the horses' conformation. Transitions will be smooth, without interruption of forward motion. The horse will exhibit a pleasant look, with clear, bright eyes

and a willing attitude. Credit will be given to fluid movement and correct cadence.

M. Exhibitors are encouraged to exhibit their horse making full use of a longing circle having a 25' radius (7.5m).

N. An exhibitor may only show two horses in each longe line class. The same exhibitor must show in both segments of the class. An additional handler may hold the second horse while the first horse is being worked. An additional handler may hold the first horse while the second horse is being worked. A maximum of two handlers may be used. In Amateur classes, any additional handlers must hold a current APHA Amateur card. Exhibitors and handlers may not do anything to disturb any horses in the class while they change handlers.

O. Scoring.

1. Movement will count for *34 points* of the total score.

a. Walk. The walk will be scored on a scale of *1-3* in each direction, with *2* being average. The horse must be walked long enough for the judge to have sufficient time to evaluate and score the walk. Lower gait scores should reflect stumbling in the gait.

b. Jog or Trot. The jog/trot will be scored on a scale of *1-7* in each direction. Using a 25' radius (7.5m), the horse should jog or trot a minimum of *1/2* circle both directions of the ring. Lower gait scores should reflect stumbling in the gait.

c. Lope or Canter. The lope/canter will be scored on a scale of *1-7* in each direction. Using a 25'

radius, the horse should lope or canter a minimum of one full circle both directions of the ring. Lower gait scores should reflect stumbling in the gait.

2. Manners/Expression/Attitude will count for up to *14 points* of the total score. Horses will be penalized for obvious signs of overwork and sourness such as ear-pinning, head-throwing, striking, tail wringing, or a dull, lethargic manner of going. They will also be penalized for dangerous behavior such as excessive bucking, cutting into the circle, or running off. Additionally, incidental touching the horse with the whip, cross-cantering, balking, backing up on the longe line and excessive urging from the exhibitor should be penalized accordingly.

3. Conformation will count for up to *6 points* of the total score. The horse will be judged on conformation suitable to future performance as a Western Pleasure or Hunter Under Saddle competitor. The judges should look for a total picture, emphasizing balance, structural correctness, and athletic capability.

4. Use of the circle. Consideration will be given to how well or how poorly the horse/exhibitor team uses the 25' radius (7.5m) of the longing circle. A separate box on the scorecard is available to indicate an overall score (*from 1-3 points*) for use of the circle. Circle Scores: As described earlier, a 25' radius (7.5m) is the appropriate size of circle in which to show a longe liner. It is the judge's responsibility to evaluate the circles and incorporate use of the circle in the

gait scores based on the following scale:

- +3 points (Good to Excellent Use of the Circle).** Horse consistently stays on the perimeter of the circle with slight looseness in the line. Horse turns around on the circle perimeter.
 - +2 points (Average use of the circle).** Horse is only slightly inconsistent in using the 25' radius (7.5m) of the circle.
 - +1 point (Adequate use of the circle)** Horse is shown in a circle radius of less than 25' (7.5m).
 - 0 points (General use of the circle)** Potentially dangerous slack in the line. Horse pulls exhibitor out of the circle.
- 5. Other scoring considerations:** This class should be looked upon as a class that defines what it means to be a "pleasure prospect" or "hunter prospect" suitable to become a future performer under saddle. Therefore, attitudes and attributes that contribute to becoming a future performer will be rewarded within the gait scores. Higher gait scores will reflect: Above average to exceptional manners, expression, alertness, responsiveness, and pleasant attitude, above average to exceptionally smooth transitions between gaits, above average to excellent cadence and consistency at all three gaits.
- 6. Penalties and disqualifications.**
- a. Five (5)-point penalties *per direction*.**
 - 1. Failure to walk a minimum of two horse lengths.**

- 2. Failure to jog/trot a minimum of ¼ (quarter) of a circle.**
- 3. Failure to demonstrate the correct lead for a minimum of ¼ (quarter) of a circle.**
- b. Disqualification will occur in the following instances: Evidence of lameness—judge will immediately excuse horse from the arena, blatant striking horse with the whip during the longing demonstration that will cause forward or lateral movement, horse falls—A horse is considered to have fallen when it is on its side and all four legs are extended in the same direction, horse steps over or becomes entangled in the longe line, failure to show at all three gaits in both directions, loss of control of the horse to the point that the horse is loose in the arena, exhibitor disrespect towards the judge(s).**

Related rules SC.325.K.2.h, AM-095.C & E

Control SC-270

Rule SC-270., addition to read. Western Attire and Tack - Roping, Speed Events, Team Penning and Ranch Sorting,

- B. WESTERN TACK.** Western type equipment must be used **with the exception of bits and mouthpieces.** Acceptable western or English bits or mouthpieces may be used if they meet bit specifications outlined in SC-200 and SC-240. Horses shall be shown with a stock saddle; silver equipment will not count over a good working outfit. Bridle

may be either a standard plain or silver headstall with a brow band, shaped ear or split ear. (See equipment and attire chart in back of rule book.)

Control SC-276

Rule SC-276., additions to read. Ranch Sorting.

- B. OBJECTIVE: Ranch Sorting is a timed event consisting of two riders with the objective of sorting ten head of cattle from one pen into another in a designated sequence. The team that sorts all ten head in the correct order with the fastest time will be declared the winner. A Ranch Sorting run begins with ten numbered cattle, 0-9, and ~~two~~ **one** unnumbered ~~cattle~~ **cow** for a total of ~~12~~ **11** head behind a foul line in an arena with two people mounted on the other side of the foul line.
- O. COW LEAVING THE ARENA: If a good cow jumps any fence and either leaves the arena, or ends up in the opposite pen, but did not pass through the gate, **the run should be stopped and the team given 2 options** ~~it will result in a re-ride for that team at the end of the herd,~~ (assuming it was not caused by roughing). ~~and time cannot be improved.~~
- 1. Take the number of cattle sorted and time at time of infraction.**
 - 2. Given a re-ride from scratch at the end of the herd.**

Control SC-284

Rule SC-284., new rule to read. Timed Team Roping.

- A. Loops. Only two loops per team shall be allowed. Roping steers without turning loose the loop will be considered no catch. Roper must dally to stop steer.

If steer is roped by one horn, roper is not allowed to ride up and remove loop or put loop over other horn or head with hands.

- B. Legal Catches. There are only three legal head catches:
- 1. Around both horns.**
 - 2. Half a head.**
 - 3. Around the neck.**
- C. If hondo passes over one horn and the loop over the other, catch is illegal. If a loop crosses itself in a head catch, it is illegal. This does not include heel catches. If rope is in steer's mouth, catch is illegal.
- D. Any heel catch behind both shoulders is legal if rope goes up both heels.
- 1. One hind foot receives five-second penalty.**
- E. Crossfire. The header must have control of the steer's head and the steer's head must be bent before the heeler can legally deliver his rope. The heeler may rope the steer in the switch, but not before. Any heel loop delivered before the switch is considered a crossfire and illegal. In the instance where a steer sets up, at no fault of the roper, the heel loop can be thrown at any time once the header has control of the steer.
- F. Questioned Catch. Any questioned catches will be decided by the judges. If judge asks the header to hold the steer so the flagger may inspect the head catch, and the header does not do so, the team may receive a no-time.
- G. Time Taken. Time will be taken when the steer is roped, secure between both partners, both horses are facing steer with ropes dallied and tight. Horse's front feet must be on the ground and ropers must be mounted when time is taken. Steer must be

standing up when roped by head or heels. Time is taken when flag is dropped; however, that time is not official until indication is given by flagger or judge to the timer. Flagger may flag a team out after time is taken on a run, based on illegal head catch or illegal heel catch, steer was not secure or any other factor that was not clear when time was taken.

H. **Tie On Rule.** Any heeler 60 years or older and adult women of any age may tie on. Under no circumstances will any header be permitted to tie on. It is illegal to dally over the top of a tied on rope or tie on device, the result is automatic disqualification.

Furthermore, should a tied on rope inadvertently come loose from the saddle horn or otherwise become detached during the course of a run, the team will be disqualified. The roper may not reattach his rope or dally with a loose tied on rope. Ropers who tie on are encouraged to use a quick release for tied on ropes.

I. **Heeler Ropes Front Foot.** If the heeler ropes a front foot or feet in the heel loop, this is a foul catch. Should the front foot or feet come out of the heel loop prior to the team calling for time, the time will be counted. Judge will not allow any extra time for a front leg to come free.

J. **Header Ropes Any Leg.** Should a header rope any leg, it's an automatic no-time. Under no circumstance will the header be allowed to fish-out the leg.

K. **Dropped Rope.** A dropped rope that must be recoiled is considered a thrown rope.

L. **Arena Clear.** Should a team call for a steer before the arena is clear, and are subsequently interfered with by the

steer or team still in the arena, this should not be recognized as interference and they shall not receive a re-run.

M. **Steer must not be handled roughly at any time, and ropers will be disqualified if in the opinion of the field judge they have intentionally done so.**

N. **If header accidentally jerks steer off his feet or steer trips or falls, header must not drag steer over approximately eight feet before steer regains his feet or the team will be disqualified.**

O. **If either horse takes longer than 30 seconds to enter the box after the judge has signaled the course ready, the entry shall be disqualified.**

Control SC-285 (amended)

Rule SC-285., change to read. **Team Roping/Steer Stopping**

E. **JUDGING HEELING HORSE.**

1. The heeling horse shall be judged in the box on ease of manner in which he turns and prepares for heeler's position to throw loop, set and stop steer while holding rope tight in preparation for header's facing.

~~2. When heeling horse is being judged, a headloop must be placed on the steer's head or horns before the animal leaves the chute.~~

3. The header may throw a maximum of two loops. If the header fails to catch with either loop, they are to retire from the arena with no score.

~~4. When heeling horse is being judged, the roper~~ **The heeler** may throw only two loops. If roper misses with both loops, they are to retire from the arena with no score.

5. A legal **heel** catch is defined as a catch which holds from behind the steer's shoulders and back, around

the flank, or on one or both heels, but not by the tail only.

6. ***In classes with five entries or less, show management may choose to use a head loop placed on the steer's head or horns before the animal leaves the chute.***
 - a. ***Show management must inform exhibitors of this decision prior to the class starting.***
 - b. ***All exhibitors in a class are required to compete using the same class procedures.***
7. The rider must dally on the horse being judged.
8. The horse/rider not being judged may ~~tie~~, dally or pull tight.

Related rule SC-285.C.7.b.2 ***Any catch by the header not being judged must be a legal catch defined as a catch that is around both horns, half a head, or around the neck.***

Control SC-285-1

Rule SC-285., new 9 to read. Team Roping/Steer Stopping

C. GENERAL RULES.

9. **Tie On.** Any heeler 60 years or older and adult women of any age may tie on. Under no circumstances will any header be permitted to tie on. Heelers who tie on are required to use a quick release for tied on ropes.

Related Rules:

AM-135. Any Amateur heeler 60 years or older and adult women of any age may tie on. Under no circumstances will any header be permitted to tie on. Heelers who tie on are required to use a quick release for tied on ropes.

SC-285.D.5 *The horse/rider not being judged may ~~tie~~, dally or pull tight.*

Control SC-302

Rule 302., new rule. RANCH HORSE PLEASURE.

- A. The purpose of Ranch Horse Pleasure horse should reflect the versatility, attitude, and movement of a working horse. The horse's performance should simulate a horse riding outside the confines of an arena and that of a working ranch horse. This class should show the horse's ability to work at a forward, working speed while under control by the rider. Light contact should be rewarded and horse shall not be shown on a full drape of reins. The overall manners and responsiveness of the horse while performing the maneuver requirements, and the horse's quality of movement are the primary considerations.
- B. Offered as an all age class for open, amateur and youth and for horses three years of age or older.
- C. No horse may cross enter, i.e. a junior/senior western pleasure horse shown at a show is not eligible to show in the ranch pleasure at the same show; a youth or amateur western pleasure horse shown at a show is not eligible to show in the ranch pleasure

at the same show, etc.

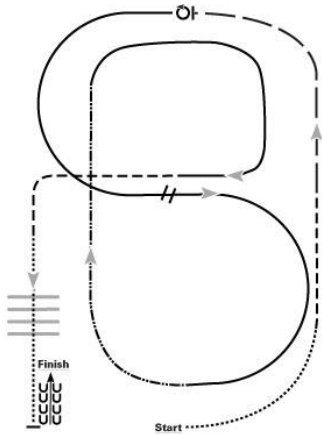

RANCH PLEASURE -- PATTERN 1

1. Walk
2. Jog
3. Extend the jog ,at the top of the arena ,stop
4. 360 turn to the left
5. Left lead 1/2 circle, lope to the center
6. Change leads (simple or flying)
7. Right lead 1/2 circle
8. Extended lope up the long side of the arena (right lead)
9. Collect back to a lope around the top of the arena and back to center
10. Break down to a jog
11. Walk over poles
12. Stop and back

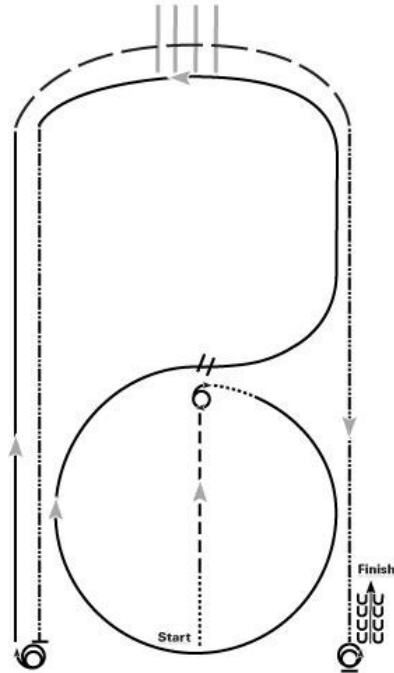

RANCH PLEASURE -- PATTERN 2

1. Walk
2. Jog
3. Stop, do 1 1/4 turn to the right
4. Walk
5. Lope small circle on the right lead
6. Change leads, (simple or flying)
7. Lope left lead around end of the arena
8. Extend the lope on the left lead
9. Stop, do 2 1/2 turns right
10. Lope straight on the right lead
11. Extend the jog around end of the arena
12. Cross poles
13. Extend lope on right lead
14. Stop, do 2 turns left
15. Back

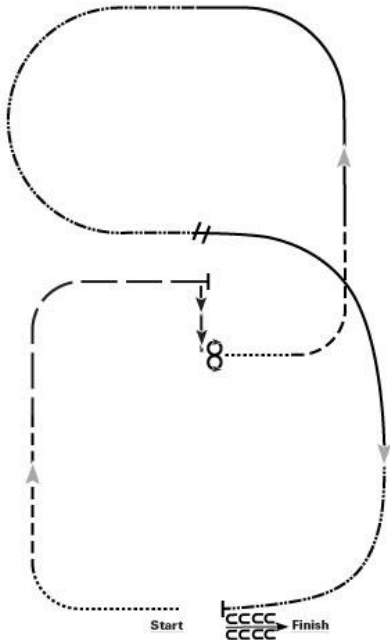

RANCH PLEASURE -- PATTERN 3

1. Walk to the left around corner of the arena
2. Jog
3. Extend alongside of the arena and around the corner to center
4. Stop, side pass right
5. 360 turn each direction (either way 1st)
6. Walk
7. Jog
8. Lope left lead
9. Extend the lope
10. Change leads (simple or flying)
11. Collect to the lope
12. Extend the lope
13. Stop and back

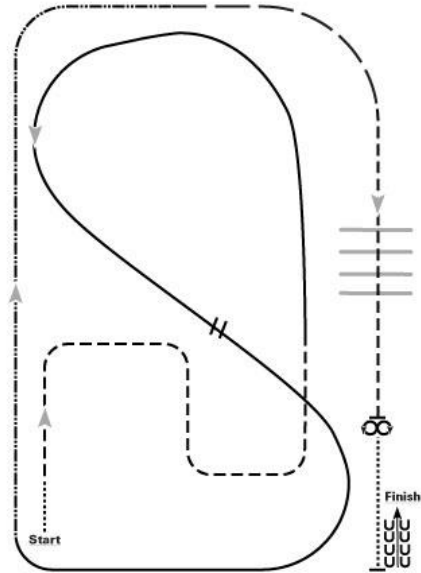

RANCH PLEASURE -- PATTERN 4

1. Walk
2. Jog serpentine
3. Lope left lead around the end of the arena and then diagonally across the arena
4. Change leads (simple or flying) and
5. Lope on the right lead around end of the arena
6. Extend lope on the straight away and around corner to the center of the arena
7. Extend jog around corner of the arena
8. Collect to a jog
9. Jog over poles
10. Stop, do 360 turn each direction (either direction 1st) (L-R or R-L)
11. Walk, stop and back

D. Class requirements:

1. Each horse will work individually, performing both required and optional maneuvers, and scored on

- the basis of 0 to 100, with 70 denoting an average performance.
2. The required maneuvers will include the walk, jog, and lope both directions: and the extended jog and extended lope at least one direction; as well as stops, and back.
 3. Three optional maneuvers may include a side pass, turns of 360 or more, change of lead (simple or flying), walk, jog, or lope over a pole(s); or some reasonable combination of maneuvers that would be reasonable for a ranch horse to perform.
 4. The maneuvers may be arranged in various combinations with final approval by the judge.
 5. The overall cadence and performance of the gaits should be as those described in GAITS, with an emphasis on forward movement, free-flowing, and ground covering for all gaits. Transitions should be performed where designated, with smoothness and responsiveness.
 6. No time limit.
 7. One of the suggested four patterns may be used, however a judge may utilize a different pattern as long as all required maneuvers and the three (or more) optional maneuvers are included.
- E. Ranch Horse Apparel and Equipment
1. No hoof polish.
 2. No braided or banded manes or tail extensions.
 3. Trimming inside ears is discouraged.
 4. Trimming bridle path is allowed, also trimming of fetlocks or excessive (long) facial hair.
 5. Equipment with silver should not count over a good working outfit. Silver on bridles and saddles is discouraged.
- F. Ranch Horse Apparel and Equipment
1. No hoof polish.
 2. No braided or banded manes or tail extensions.
 3. Trimming inside ears is discouraged.
 4. Trimming bridle path is allowed, also trimming of fetlocks or excessive (long) facial hair.
 5. Equipment with silver should not count over a good working outfit. Silver on bridles and saddles is discouraged.
- G. Ranch Horse Penalties. A contestant shall be penalized each time the following occur:
1. One (1) point penalties
 - a. Too slow/per gait
 - b. Over-Bridled
 - c. Out of Frame
 - d. Break of gait at walk or jog for 2 strides or less
 - e. Split log at lope
 2. Three (3) point penalties
 - a. Break of gait at walk or jog for more than 2 strides
 - b. Break of gait at lope
 - c. Wrong lead or out of lead
 - d. Draped reins
 3. Five (5) point penalties
 - a. Blatant disobedience (kick, bite, buck, rear, etc.)
 4. Placed below horses performing all maneuvers
 - a. Eliminates maneuver
 - b. Incomplete maneuver
 5. Zero (0) score
 - a. Illegal equipment
 - b. Willful abuse
 - c. Major disobedience or schooling

Control SC-312

Rule SC-312., new Rule to read.

Competitive Trail Horse.

- A. **GENERAL RULES.** This APHA-approved special event is a Competitive Trail Ride, obstacles are mostly natural, and each has its own judge, alleviating partiality. The Trail Challenge is a competitive trail ride, 6 miles with 6 obstacles, 6 judges. The Obstacle Challenge is an obstacle challenge it is off the trail with 8 obstacles in arena or field.
- B. Competitions will be held at existing events hosted by the American Competitive Trail Horse Association (ACTHA) and must be approved by the ACTHA before application is forwarded for approval by the APHA as a special event.
- C. Classes may be offered in all divisions (Open, Amateur, Novice Amateur, Youth and Novice Youth) and in both the Regular Registry and Solid Paint-Bred divisions.
- D. All APHA Youth and Amateur program rules regarding eligibility and ownership apply.
- E. **AWARDS AND RECOGNITION:**
 - 1. Current APHA point system will apply.
 - 2. Horses earning American Trail Horse Association points are eligible for APHA Register of Merit, Superior Event, APHA Champion, Performance Versatility, and Honor Roll awards only. Points in this class will not count towards any other awards including Breeders' Trust payouts.
- F. See American Competitive Trail Horse Association for specific rules governing each class. Rules are available from

American Competitive Trail Horse Association, P.O. Box 341047 Austin, TX, 78734 | 877-992-2842.

Control SC-325

Rule SC-325. K. 1. d., delete and replace with.

- d. It is mandatory that all approved shows select Grand and Reserve Champions in each sex division. See Rule SC-065. APHA will so note the awarding of the title of Grand Champion and Reserve Champion Stallion, Mare and Gelding on the performance record only when at least three horses are exhibited in that sex division.

RELATED RULES:

AM-090. C. 3. E. 1., delete as follows.

~~1. The selection of Solid Paint-Bred Grand and Reserve Champion will be optional.~~

Control AM-020

Rule AM-020.A.1., addition to read.

EXCEPTION:

- 1. Amateurs are eligible to show leased horses with the following guidelines:
 - a. In APHA-approved shows in Zones 12, 13 and 14 only.
 - b. The lease must be to an individual only.
 - c. The leased horse may be shown by the amateur leasing the horse. Immediate family members (see AM-020.A.) and trainers are allowed to exhibit the horse as well.
 - d. The lessee must be responsible for all expenses relating to the horse, and records must be made available to APHA upon request.
 - e. An International Performance Lease Form must be filed with

- APHA prior to exhibition of the leased horse.
- f. An International Performance Lease Certificate from the APHA office must be presented at the time the horse is to be shown by the lessee.
 - g. All Performance Leases expire on December 31 of the year submitted, and must be renewed annually to remain in effect.
 - h. Only one lease covering a horse will be recognized at a time.
 - i. There is no limit to the number of horses that an individual can lease during any given period of time.
2. For the lease of a horse to be recognized by the Association to establish ownership eligibility in APHA-approved shows or contests (International Performance Lease), written notice of its existence shall be filed with the Association on forms provided by APHA, signed by both the lessor and lessee, and submitted with applicable fees (see fee schedule at front of the Rule Book) and accompanied by a copy of certificate (both front and back). The notice shall provide the effective date of the lease.
 3. Ownership eligibility recognized by an International Performance Lease will follow those set forth in Rule AM-020.A. The lessor and their family will not be recognized as owners for competition purposes during the lease period.
 4. Any points, awards or money earned by the lessee during the lease period will be considered the lessee's. Any Breeders' Trust money earned by the horse during the lease period will be sent to the lessee recorded as of December 31 of that point year. If the lease is terminated prior to December 31, any Breeders' Trust money will be paid out to the current recorded owner as of December 31 of that point year.
5. All International Performance Leases expire on December 31 of the year submitted, and must be renewed annually to remain in effect. If it is necessary that the lease be canceled prior to the termination date provided, it may be terminated by written notice giving termination date, signed by both the lessor and lessee. No additional fee shall be charged for termination, whether automatic or by subsequent notice thereof.
 6. In regard to Association procedures, recordation of notice of lease authorizes a lessee to execute all documents pertaining to the recognized activities regardless of any limitations in the actual lease agreement. Enforcement against the lessee of limitation on the use of the horse and/or any other terms of the contract or lease, is the sole responsibility of the lessor.
 7. Horses may not be leased to a third party at any time, and such action will not be recognized by the Association.
 8. During the effective term of the lease, the Association will not record subsequent changes in ownership until the lease is terminated, unless the transfer shows the lessee as the new buyer. The date of sale in such a case will become the date the lease is terminated.
- Control AM-020 - 1 (new)**
Rule AM-020.A.1., addition to read.
EXCEPTION:
1. Amateurs are eligible to show leased horses with the following guidelines:

- a. In APHA-approved shows.
 - b. The lease must be to an individual only.
 - c. The leased horse may be shown by the amateur leasing the horse. Immediate family members (see AM-020.A.) and trainers are allowed to exhibit the horse as well.
 - d. The lessee must be responsible for all expenses relating to the horse, and records must be made available to APHA upon request.
 - e. A Performance Lease Form must be filed with APHA prior to exhibition of the leased horse.
 - f. A Performance Lease Certificate from the APHA office must be presented at the time the horse is to be shown by the lessee.
 - g. All Performance Leases expire on December 31 of the year submitted, and must be renewed annually to remain in effect.
 - h. Only one lease covering a horse will be recognized at a time.
 - i. There is no limit to the number of horses that an individual can lease during any given period of time.
2. For the lease of a horse to be recognized by the Association to establish ownership eligibility in APHA-approved shows or contests (Performance Lease), written notice of its existence shall be filed with the Association on forms provided by APHA, signed by both the lessor and lessee, and submitted with applicable fees (see fee schedule at front of the Rule Book) and accompanied by a copy of certificate (both front and back). The notice shall provide the effective date of the lease.
3. Ownership eligibility recognized by a Performance Lease will follow those set forth in Rule AM-020.A. The lessor and

their family will not be recognized as owners for competition purposes during the lease period.

4. Any points, awards or money earned by the lessee during the lease period will be considered the lessee's. Any Breeders' Trust money earned by the horse during the lease period will be sent to the lessee recorded as of December 31 of that point year. If the lease is terminated prior to December 31, any Breeders' Trust money will be paid out to the current recorded owner as of December 31 of that point year.

5. All International Performance Leases expire on December 31 of the year submitted, and must be renewed annually to remain in effect. If it is necessary that the lease be canceled prior to the termination date provided, it may be terminated by written notice giving termination date, signed by both the lessor and lessee. No additional fee shall be charged for termination, whether automatic or by subsequent notice thereof.

6. In regard to Association procedures, recordation of notice of lease authorizes a lessee to execute all documents pertaining to the recognized activities regardless of any limitations in the actual lease agreement. Enforcement against the lessee of limitation on the use of the horse and/or any other terms of the contract or lease, is the sole responsibility of the lessor.

7. Horses may not be leased to a third party at any time, and such action will not be recognized by the Association.

8. During the effective term of the lease, the Association will not record subsequent changes in ownership until the lease is terminated, unless the transfer shows the lessee as the new buyer. The date of sale

in such a case will become the date the lease is terminated.

Control AM-145

Rule AM-145., add new rule. Amateur Limited Working Ranch Horse.

- A. For rules governing this event other than those listed in this rule, see Rule SC-301.**
 - 1. Riders cannot have shown down the fence 3 actual runs in any judged classes or events with the exception of horse sales. Being entered in a class which includes the fence work will be counted as going down the fence regardless if the rider boxed the cow and pulled up before the run was completed. The responsibility for eligibility lies with the competitor. If an individual feels a competitor is not eligible for a class, the burden of proof lies with the person who protests.**
 - 2. After Amateur competitors reach the age of 50, they may fall back into the Limited Amateur class. However, they may not go down the fence again in any judged classes or events with the exception of horse sales and remain in the Limited Amateur class. Competitors may fall back to the Limited Amateur class only one time.**
- B. COW WORK GUIDELINES. The goal of this class is to introduce the rider to the “boxing” phase of the cow work. For complete scoring guidelines, see Rule AM-255.**
- C. Points earned in this class will count for all APHA Amateur awards.**

RELATED RULES:

YP-156., add new rule. Youth Limited Working Ranch Horse

- A. For rules governing this event other than those listed in this rule, see Rule YP-155.**
 - 1. Riders cannot have shown down the fence 3 actual runs in any judged classes or events with the exception of horse sales. Being entered in a class which includes the fence work will be counted as going down the fence regardless if the rider boxed the cow and pulled up before the run was completed. The responsibility for eligibility lies with the competitor. If an individual feels a competitor is not eligible for a class, the burden of proof lies with the person who protests.**
- B. COW WORK GUIDELINES. The goal of this class is to introduce the rider to the “boxing” phase of the cow work. For complete scoring guidelines, see Rule YP-155.**
- C. Points earned in this class will count for all APHA Youth awards.**

Control AM-205-3

Rule AM-205. A. 5., change to read.

- 5. Renewed Eligibility for Novice Amateur status. An individual who previously became ineligible for Novice Amateur status in a category due to the point restriction, World or Reserve World Championship title, or earnings, may have their Novice Amateur status in that category restored if, in the 10 years prior to their re-application, they have not **earned ten (10) or more APHA and/or other associations’ revalued performance points (ROM)**, money or a World Champion or Reserve World**

Champion title in any recognized equine association, in that category, including but not limited to APHA, AQHA, ApHC, IBHA, PHBA, PtHA, AHA, AMHA, ABRA, POA, NCHA, NBHA **and/or** NRHA.

Control AM-255

Rule AM-255., addition to read. Novice Amateur Working Ranch Horse.

- A. For rules governing this event other than those listed in this rule, see Rule SC-301.
- 1. Riders cannot have shown down the fence 3 actual runs in any judged classes or events with the exception of horse sales. Being entered in a class which includes the fence work will be counted as going down the fence regardless if the rider boxed the cow and pulled up before the run was completed. The responsibility for eligibility lies with the competitor. If an individual feels a competitor is not eligible for a class, the burden of proof lies with the person who protests.**

RELATED RULES:

YP-250., addition to read. Novice Youth Working Ranch Horse

- A. For rules governing this event other than those listed in this rule, see Rule SC-301.
- 1. Riders cannot have shown down the fence 3 actual runs in any judged classes or events with the exception of horse sales. Being entered in a class which includes the fence work will be counted as going down the fence regardless if the rider boxed the cow and pulled up before the run was completed. The responsibility for eligibility lies**

with the competitor. If an individual feels a competitor is not eligible for a class, the burden of proof lies with the person who protests.

Control AM-300

AM-300. C. ELIGIBILITY. Change to read:

C. All participants in this division must meet Amateur Eligibility as outlined in AM-010, and hold a current Amateur Card, which will be applied for annually and limit the exhibitor to those classes only for that calendar year. He or she MAY also enter halter, showmanship, yearling in-hand trail and yearling longe line classes, but MAY NOT enter any lope classes at any show where APHA-approved classes are held. **If a Walk-Trot cardholder chooses to show in Walk-Trot Showmanship, he/she MAY NOT enter the Amateur and/or Novice Amateur Showmanship at that same event; if a Walk-Trot cardholder prefers to show in Novice Amateur and/or Amateur Showmanship, he/she MAY NOT enter the Walk-Trot Showmanship.** If no Walk-Trot classes are offered for this age group, the exhibitor cannot show in any other division (unless otherwise specified) unless he/she reclassifies. Reclassification prevents the exhibitor from showing in Walk-Trot classes for the remainder of that calendar year. The exhibitor may reapply the following year for classification in walk-Trot.

Control AM-300-2

Rule AM-300. E., addition to read. Points.

- E. Points earned in this class will count toward APHA Amateur Walk-Trot, Register of Merit Superior Event, Honor Roll, **Top 20 10 and Zone** awards only. Points in this class will not count toward any other APHA awards including Breeders' Trust payouts.

RELATED RULES

AM-060. A., change to read.

4. ~~Amateur Solid Paint-Bred~~ **Amateur Walk-Trot – Top 10**
5. **Amateur Solid Paint Bred- Top 10**

AM-060. C., change to read.

1. Eligible Points, Pointed earned...are eligible for this award. **For Walk-Trot, points earned in events listed in AM-300. F. are eligible for this award.** For Solid Paint-Bred...are eligible for this award.

AM-070. A., change to read.

4. ~~Amateur Solid Paint-Bred~~ **Amateur Walk-Trot**
5. **Amateur Solid Paint-Bred**

AM-070. B., addition to read.

2. Eligible Points. Points earned...are eligible for this award. **For Walk-Trot, points earned in events listed in AM-300. F. are eligible for this award.** For Solid Paint-Bred...are eligible for this award.

Control AM-300-3

Rule AM-300, change to read. Amateur Walk-Trot Division

- D. **OWNERSHIP. All participants in this division must meet the ownership requirements as outlined in AM-020. A horse exhibited in Amateur Walk-Trot classes does not have to be owned by the contestant showing the horse. However, in order to be eligible for the various APHA points, titles and awards sponsored by the APHA, the horse must be owned by the Amateur Walk-Trot exhibitor and/or the Amateur Walk-Trot exhibitor's family (mother, father, stepparent, brother, sister,**

stepbrother, stepsister, half-brother, half-sister, aunt, uncle, nephew, niece, inlaw (brother, sister), legal guardian, grandparent or step-grandparent), family owned corporation, ranch or farm. Such ownership must be evidenced by the records of the APHA. Throughout the rest of these rules, the above shall stand as ownership requirements. See Rule GR-020.K.1. and RG-035.B.1.

1. **Horses Under Lease. Horses under lease to, but not owned by any of the above named persons, do not qualify for the APHA Amateur Walk Trot points and/or awards.**
2. **Horses Owned In Partnership. Horses owned in partnership or jointly with any person other than those listed above are not eligible for APHA Amateur Walk Trot points or awards. To be eligible to earn APHA points, the Amateur Walk Trot exhibitor must be related to each name listed on the horse's registration certificate and/or every owner of the farm/business/partnership.**
3. **Horses Registered In The Name Of A Non-Family Owned Farm Or Ranch. Horses registered in the name of a farm or ranch other than the Novice Amateur's family as listed above are not eligible for APHA Amateur Walk Trot points or awards.**
4. **Exhibitors not meeting ownership requirements will lose any APHA points earned but will maintain placings.**
5. **The total number of entries in the class and the placings of the other exhibitors will not change.**

Control YP-015

Rule YP-015.A.2., addition to read.

EXCEPTION:

- 1. Youth are eligible to show leased horses with the following guidelines:**
 - a. In APHA-approved shows in Zones 12, 13 and 14 only.**
 - b. The lease must be to an individual only.**
 - c. The leased horse may be shown by the youth leasing the horse. Immediate family members (see YP-015.A.) and trainers are allowed to exhibit the horse as well.**
 - d. The lessee must be responsible for all expenses relating to the horse, and records must be made available to APHA upon request.**
 - e. An International Performance Lease Form must be filed with APHA prior to exhibition of the leased horse.**
 - f. An International Performance Lease Certificate from the APHA office must be presented at the time the horse is to be shown by the lessee.**
 - g. All Performance Leases expire on December 31 of the year submitted, and must be renewed annually to remain in effect.**
 - h. Only one lease covering a horse will be recognized at a time.**
 - i. There is no limit to the number of horses that an individual can lease during any given period of time.**
- 2. For the lease of a horse to be recognized by the Association to establish ownership eligibility in APHA-approved shows or contests (International Performance Lease), written notice of its existence shall be filed with the Association on forms provided by APHA, signed by both the lessor and lessee, and submitted with applicable fees (see fee schedule at front of the Rule Book) and accompanied by a copy of certificate (both front and back). The notice shall provide the effective date of the lease.**
- 3. Ownership eligibility recognized by an International Performance Lease will follow those set forth in Rule YP-015.A. The lessor and their family will not be recognized as owners for competition purposes during the lease period.**
- 4. Any points, awards or money earned by the lessee during the lease period will be considered the lessee's. Any Breeders' Trust money earned by the horse during the lease period will be sent to the lessee recorded as of December 31 of that point year. If the lease is terminated prior to December 31, any Breeders' Trust money will be paid out to the current recorded owner as of December 31 of that point year.**
- 5. All International Performance Leases expire on December 31 of the year submitted, and must be renewed annually to remain in effect. If it is necessary that the lease be canceled prior to the termination date provided, it may be terminated by written notice giving termination date, signed by both the lessor and lessee. No additional fee shall be charged for termination, whether automatic or by subsequent notice thereof.**
- 6. In regard to Association procedures, recordation of notice of lease authorizes a lessee to execute all documents pertaining to the recognized activities regardless of any limitations in the actual lease agreement. Enforcement against the lessee of limitation on the use of the horse and/or any other terms of the**

contract or lease, is the sole responsibility of the lessor.

7. Horses may not be leased to a third party at any time, and such action will not be recognized by the Association.
8. During the effective term of the lease, the Association will not record subsequent changes in ownership until the lease is terminated, unless the transfer shows the lessee as the new buyer. The date of sale in such a case will become the date the lease is terminated.

Control YP-015-1 (new)

Rule YP-015.A.2., addition to read.

EXCEPTION:

1. Youth are eligible to show leased horses with the following guidelines:
 - a. In APHA-approved shows.
 - b. The lease must be to an individual only.
 - c. The leased horse may be shown by the youth leasing the horse. Immediate family members (see YP-015.A.) and trainers are allowed to exhibit the horse as well.
 - d. The lessee must be responsible for all expenses relating to the horse, and records must be made available to APHA upon request.
 - e. A Performance Lease Form must be filed with APHA prior to exhibition of the leased horse.
 - f. A Performance Lease Certificate from the APHA office must be presented at the time the horse is to be shown by the lessee.
 - g. All Performance Leases expire on December 31 of the year submitted, and must be renewed annually to remain in effect.
 - h. Only one lease covering a horse will be recognized at a time.
- i. There is no limit to the number of horses that an individual can lease during any given period of time.
2. For the lease of a horse to be recognized by the Association to establish ownership eligibility in APHA-approved shows or contests (Performance Lease), written notice of its existence shall be filed with the Association on forms provided by APHA, signed by both the lessor and lessee, and submitted with applicable fees (see fee schedule at front of the Rule Book) and accompanied by a copy of certificate (both front and back). The notice shall provide the effective date of the lease.
3. Ownership eligibility recognized by a Performance Lease will follow those set forth in Rule YP-015.A. The lessor and their family will not be recognized as owners for competition purposes during the lease period.
4. Any points, awards or money earned by the lessee during the lease period will be considered the lessee's. Any Breeders' Trust money earned by the horse during the lease period will be sent to the lessee recorded as of December 31 of that point year. If the lease is terminated prior to December 31, any Breeders' Trust money will be paid out to the current recorded owner as of December 31 of that point year.
5. All Performance Leases expire on December 31 of the year submitted, and must be renewed annually to remain in effect. If it is necessary that the lease be canceled prior to the termination date provided, it may be terminated by written notice giving termination date, signed by both the lessor and lessee. No additional fee shall be charged for termination, whether automatic or by subsequent notice thereof.

6. In regard to Association procedures, recordation of notice of lease authorizes a lessee to execute all documents pertaining to the recognized activities regardless of any limitations in the actual lease agreement. Enforcement against the lessee of limitation on the use of the horse and/or any other terms of the contract or lease, is the sole responsibility of the lessor.

7. Horses may not be leased to a third party at any time, and such action will not be recognized by the Association.

8. During the effective term of the lease, the Association will not record subsequent changes in ownership until the lease is terminated, unless the transfer shows the lessee as the new buyer. The date of sale in such a case will become the date the lease is terminated.

Control YP-110

Rule YP.110. D., change to read.

- D. ~~No~~ Points. Points earned in this class will count towards APHA Youth Walk Trot Register of Merit, and Superior Event *and youth zone awards*. Points in this class will not count toward any other APHA awards.

Control YP-152

Rule YP-152., change to read. Limited Youth Working Cow Horse.

- D. ~~Points earned in this class will count for ROM and Superior Event only. Points in this class will not count toward any other APHA awards.~~ Points in this class will count for all APHA Youth awards.

RELATED RULES:

AM-141., change to read. Amateur Limited Working Cow Horse.

- D. ~~Points earned in this class will count for ROM and Superior Event only. Points in this class will not count toward any other APHA awards.~~ Points in this class will count for all APHA Amateur awards.

AM-030., change to read. Performance Contest Categories.

4. Category IV

- h. Limited Working Cow Horse (~~eligible for ROM and Superior Event only~~)

AM-035., change to read. APHA Superior Amateur Champion Award

C. TOTAL POINTS.

2. **Performance.** At least 240 of those points have been won in the Amateur performance classes specified in Rule AM-030, excluding ~~categories category VIII-X. and Limited Working Cow Horse.~~
3. **Superior Event.** Have earned a Superior in four (4) of the categories specified in Rule AM-030, excluding ~~categories category VIII-X. and Limited Working Cow Horse.~~
4. **ROM Requirement.** Have earned a ROM in four (4) of the categories specified in Rule AM-030, excluding ~~categories category VIII-X, and Limited Working Cow Horse,~~ in an event other than that in which the qualifying Superiors were won.

AM-040., change to read. APHA Amateur Champion Award.

C. POINTS.

3. **Performance.** That at least sixteen (16) of these points have been won in Amateur Performance classes or contests, and with a minimum of five (5) points each have been earned in at least two (2) categories

of Amateur performance events and cannot be earned in a combination of categories, as set forth in Rule AM-030. NOTE: Only Categories I through V, VII and IX (~~except Limited Working Cow Horse~~) will be used for tabulation of the sixteen (16) Amateur performance points for an Amateur Champion.

4. **Remaining Points Needed.** The remaining eight (8) points may be earned in any Amateur events listed in Rule AM-030 or AM-090, excluding VIII ~~and X. and Limited Working Cow Horse.~~

AM-060., change to read. APHA Amateur Top 20 Awards.

C. Maximum Number of Shows and Judges Counted

1. Eligible Points. Points earned in events listed in AM-090.C and AM-095.B-C, excluding Yearling Longe Line, Yearling In-Hand Trail, ~~Amateur Limited Working Cow Horse,~~ Cowboy Mounted Shooting and Dressage are eligible for this award. For Solid Paint-Bred, points earned in events listed in AM-090.D and AM-095.D-E, excluding Yearling Longe Line, Yearling In-Hand Trail, ~~Amateur Limited Working Cow Horse,~~ Cowboy Mounted Shooting and Dressage are eligible for this award.

AM-065., change to read. APHA Amateur Honor Roll Award.

B. POINTS.

2. ~~Limited Working Cow Horse,~~ Yearling Longe Line and Yearling In-Hand Trail points do not count towards this award.

AM-070., change to read. APHA Amateur Zone Awards.

B. POINTS.

2. Eligible Points. Points earned in events listed in AM-090.C and AM-095.B-C, excluding Yearling Longe Line ~~and Yearling In-Hand Trail and Amateur Limited Working Cow Horse~~ are eligible for this award. For Solid Paint-Bred, points earned in events listed in AM-090.D and AM-095.D-E, ~~excluding Amateur Limited Working Cow Horse~~ are eligible for this award.

AM-225., change to read. APHA Novice Amateur Honor Roll Award.

- A. Points earned in events listed in AM-250, ~~excluding Limited Working Cow Horse,~~ are eligible for this award.

YP-025., change to read. Performance Contest Categories.

A. CATEGORIES.

4. **Category IV**
 - h. Youth Limited Working Cow Horse (~~eligible for ROM and Superior Event only~~)

YP-030., change to read. APHA Superior Youth Champion Award.

C. POINTS.

2. **Performance.** At least 240 of those points have been won in the Youth performance classes specified in Rule YP-025, excluding ~~Youth Limited Working Cow Horse and~~ categories VIII and IX.
3. **Superior Event.** Have earned a Superior in four (4) of the categories specified in Rule YP-025, ~~excluding Youth Limited Working Cow Horse and~~ categories VIII and IX.

4. **ROM.** Have earned a ROM in four of the categories specified in Rule YP-025, excluding ~~Youth Limited Working Cow Horse~~ and categories VIII and IX, in an event other than that in which the qualifying Superiors were won.

YP-035. APHA Youth Champion Award

C. POINTS.

3. Performance Points. That at least sixteen (16) of these points have been won in youth performance classes or contests, and with a minimum of five (5) points each having been earned in at least two (2) categories of youth performance events and cannot be earned in a combination of categories, as set forth in Rule YP-025. Note: Only categories I through V and VII and VIII, ~~excluding Youth Limited Working Cow Horse~~, will be used for tabulation of the sixteen (16) youth performance points for an APHA Youth Champion.
4. **Remaining Points Needed.** The remaining eight (8) points may be earned in any youth events listed in Rule YP-025. or Youth halter, ~~excluding Youth Limited Working Cow Horse~~ and category IX.

YP-040., change to read. APHA Youth Performance Versatility Award.

- C. **ROM.** To earn the title of APHA Youth Performance Versatility Award, five ROM's must have been earned in the performance events listed in Rule YP-025, ~~excluding Youth Limited Cow Horse~~. One of these ROM's must have been earned in Showmanship at Halter.

YP-055., change to read. APHA Youth Top 20 Award.

- C. Maximum Number Of Shows and Judges Counted.
 1. Eligible Points. Points earned in events listed in YP-085.B and YP-090.B-C, ~~excluding Youth Limited Working Cow Horse~~, Cowboy Mounted Shooting and Dressage are eligible for this award. For Solid Paint-Bred, points earned in events listed in YP-085.C and YP-090.EF, ~~excluding Youth Limited Working Cow Horse~~, Cowboy Mounted Shooting and Dressage are eligible for this award.

YP-060. APHA Youth Honor Roll Award

- B. Award. The Youth in each group (YP-060.A.1-3) earning the most points in each event during one calendar year will receive an appropriate award. See Rules YP-085.B.1., YP-085.C.1 & 2. and YP-090.B.-C. and E.-F., ~~with the exclusion of Youth Limited Working Cow Horse.~~

YP-065. APHA Youth Zone Award

- B. **POINTS.**
 2. Eligible Points. Points earned in events listed in YP-085.B. and YP-090.B.-C., ~~excluding Youth Limited Working Cow Horse~~, Cowboy Mounted Shooting and Dressage, are eligible for this award. For Solid Paint-Bred, points earned in events listed in YP-085.C and YP-090.E. & F, ~~excluding Youth Limited Working Cow Horse~~, Cowboy Mounted Shooting and Dressage, are eligible for this award.

Control YP-205

Rule YP-205. A., addition to read.

- e. Youth who have received remuneration for training horses or solicited for training will not be eligible for a Novice Youth card.

Control YP-220

Rule YP-220, change to read:

- A. **NOVICE YOUTH AWARDS.** Novice Youth awards are based solely on Novice Youth points earned. Upon earning 50 Novice Youth points per category, a national participation certificate will be mailed.
 1. Points are ~~not~~ eligible for **Novice** Youth Awards. Novice Youth points may ~~not~~ be used for any of the **Novice** Youth Awards (Year-End, etc.) or show all-arounds.

RELATED RULES:

If Controls YP-221 and YP-224 pass, then add to the above.

Control YP-221

Rule YP-221., new rule to read. APHA Novice Youth Superior Award.

- A. **TITLE.** The title of APHA Novice Youth superior will be awarded to any Youth and Youth/horse combination which meet the qualifying Rules YP-010, YP-015, YP-020, and these Title/Award requirements.
- B. **NO TIME LIMIT IN EARNING POINTS.** Points toward an APHA Novice Youth Superior need not be earned in any one year. They may accumulate points in eligible categories until the Youth reaches their eighteenth year age limit, or until they point out, whichever comes first.
- C. **PURPOSE.** The purpose of the Superior is to establish a record of excellence.
- D. **POINTS.** The Youth/horse combination are advanced to the Superior when

they have competed in one or more of the APHA-approved Novice Youth contests shown in Rule YP-250, and have won at least 50 points in any one event as outlined in the scale of points for contests.

- E. **CERTIFICATE.** When the title of Novice Youth Superior is awarded, a proper certificate shall be prepared for the Youth exhibitor by the APHA office.

Control YP-224

Rule YP-224., new rule to read. APHA Novice Youth Zone Award.

- A. This award would be to recognize the top five Novice Youth living in each of the zones. This award is based on total cumulative points earned within their respective zones. (See Rule SC-105.B.3.f-g. for states listed in the respective zones.)
 1. Minimum six points to qualify. To qualify for any of the Zone titles or awards, the horse must have earned at least six points in that zone during the year.
 2. Points earned in events listed in YP-215, excluding categories XVIII and XIX, are eligible for this award.
- B. **Tie Breaker System.**
 1. Horse with greatest number of performance points.
 2. The most points earned in the fewest number of shows.

RELATED RULES:

If passed the existing YP-222 Novice Youth Rookie will have to be renumbered to appear immediately following new awards.

Control YP-245

Rule YP-245., new F. to read.

- F. In APHA Novice Youth classes at shows held in Zones 12, 13 and 14 exhibitors are allowed to show a horse, regardless of age, in a snaffle bit or hackamore and may be ridden with one or two hands on the reins. Refer to SC-240.D. and E.

RELATED RULES:

SC-240 B.D.E. pg. 135-136, also add to int'l rules on pg. 322. (Also add pg. 322 to the index at back of book.)

Control YP-250

Rule YP-250., addition to read. APHA Novice Youth Working Cow Horse.

- A. For rules governing this event other than those listed in this rule, see Rule SC-265.
1. Riders cannot have shown down the fence 3 actual runs in any judged classes or events with the exception of horse sales. Being entered in a class which includes the fence work will be counted as going down the fence regardless if the rider boxed the cow and pulled up before the run was completed. The responsibility for eligibility lies with the competitor. If an individual feels a competitor is not eligible for a class, the burden of proof lies with the person who protests.
- B. **COW WORK GUIDELINES.** The goal of this class is to introduce the rider to the "boxing" phase of the cow work. For complete scoring guidelines, see Rule YP-152.
- C. Points earned in this class will count for all APHA Novice Youth awards.

RELATED RULES:

AM-260., add new rule. APHA Novice Amateur Working Cow Horse.

- A. For rules governing this event other than those listed in this rule, see Rule SC-265.
1. Riders cannot have shown down the fence 3 actual runs in any judged classes or events with the exception of horse sales. Being entered in a class which includes the fence work will be counted as going down the fence regardless if the rider boxed the cow and pulled up before the run was completed. The responsibility for eligibility lies with the competitor. If an individual feels a competitor is not eligible for a class, the burden of proof lies with the person who protests.
- B. **COW WORK GUIDELINES.** The goal of this class is to introduce the rider to the "boxing" phase of the cow work. For complete scoring guidelines, see Rule AM-141.
- C. Points earned in this class will count for all APHA Novice Amateur awards.

Control RA-000

Rule RA-000. D., change to read.

REGISTRATION REQUIREMENTS FOR STAKES RACES.

- D. To establish eligibility to participate in stakes races, all horses foaled on or after January 1, 2013 must meet the following requirements:
1. Regular Registry Horse-- must have at least one APHA Regular Registry Paint Horse in the 1st generation.
 2. ~~Solid Paint Bred Horses-- must have at least one APHA Regular Registry Paint Horse in the 1st generation and must have at least one APHA Regular Registry Paint Horse in the~~

~~second generation or must have two APHA Regular Registry Paint Horses in the 1st generation.~~

2. Solid Paint-Bred horses must have two APHA Regular Registry Paint Horses in the 1st generation or at least one APHA Regular Registry Horse in the 1st generation and at least one Regular Registry Paint Horse in the 2nd generation.

Control RA-000

Rule RA-000. D., change to read.

2. Solid Paint-Bred Horses must have two APHA Regular Registry Paint Horses in the 1st generation or at least one APHA Regular Registry Paint Horse in the 1st generation and at least one APHA Regular Registry Paint Horse in the 2nd generation.

Control RA-060

Rule RA-060. D., change to read. APHA Racing Awards and Honor Roll Awards.

- ~~3. If a horse advances from the Solid Paint-Bred Registry to the Regular Registry and has earned points, all points earned prior to the advancement will transfer with the horse to the new registry. The horse will then be eligible for any awards to be given in the regular registry as of December 31.~~
3. If horse is advanced during the current year – the horse will only be eligible for awards in the registry that the horse started under. i.e. started as a Solid Paint-Bred then would be eligible for Solid Paint-Bred awards for that year.

Rules going to Task Force for possible implementation in 2014

Control SC-160-4 (sent to task force)

Rule SC-160.P, addition to read:

- P. LAMENESS. Obvious lameness is: **The judge shall examine and check for lameness of all horses brought into any class. This is essential regardless of whether or not the competition indicates it is necessary.**
5. Obvious lameness is cause for disqualification.

Control SC-192 (sent to task force)

Rule SC-192., change to read. Yearling In-Hand Trail.

C. Scoring System.

4. Five (5) POINTS.
 - a. Dropping slicker or object required to be carried on course.
 - b. First or second cumulative refusal, balk, or evading an obstacle by shying or backing.
 - c. Letting go of gate or dropping rope gate.
 - d. Use of either hand to instill fear or praise (slight touching or tapping with one hand to cue horse in a sidepass maneuver only is acceptable).
 - e. Stepping outside the confines of, falling or jumping off or out of an obstacle with more than one foot once the foot has entered obstacle; including missing one element of an obstacle on a line of travel with more than one foot.
 - f. Blatant disobedience (including **biting**, kicking out, bucking, rearing, striking or continuously circling the exhibitor).
5. Zero (0) total score for course (disqualification).
 - a. Performing the obstacles other than in specified order.
 - b. No attempt to perform an obstacle.
 - c. Equipment failure that delays completion of pattern.
 - d. Excessively or repeatedly touching the horse.
 - e. Failure to enter, exit or work obstacle in any manner other than how it's described, including overturns of more than 1/4 turn.
 - f. Failure to follow the correct line of travel between obstacles.
 - g. Working outside designated boundary marker of the arena or course area.
 - h. Third cumulative refusal, balk, or evading an obstacle by shying or backing over entire course.
 - i. Failure to demonstrate correct gait between obstacles as designated.
 - j. Horse gets loose from exhibitor.
 - k. Leading, **backing and working obstacles** on the wrong side of the horse. **Leading, backing and working obstacles should be performed from the left side of the horse.**

Control SC-200 (sent to task force)

Rule SC-200.A.4, new i, to read:

A. English Tack

- ~~i. Bloody Mouth. In all divisions, if a horse's mouth is found to be bloody, disqualification is at the discretion of the judge.~~
- i. The judge must be observant of the noses, mouths, jaws, and bodies of all horses for raw or abused areas. If a horse's mouth, nose, jaw or any other area shows signs of broken skin, rawness, or bleeding, the horse will be disqualified from the class.**

Control SC-205 (sent to task force)

Rule SC-205.B.3. delete.

- ~~b. Horses must be shown in a regulation hunt snaffle bit with mouth piece as follows: Bars of mouthpiece must be round, smooth and unwrapped metal no less than 5/16 inch (.79cm) in diameter measured one inch in from cheek with a gradual decrease to the center of the snaffle. May be inlaid, but smooth, or rubber latex wrapped. The mouthpiece may be three pieces.~~

SC-205.B.4. delete:

- ~~b. Horses must be shown in a regulation hunt snaffle bit with mouth piece as follows: Bars of mouthpiece must be round, smooth and unwrapped metal no less than 5/16 inch (.79cm) in diameter measured one inch in from cheek with a gradual decrease to the center of the snaffle. May be inlaid, but smooth, or rubber latex wrapped. The mouthpiece may be three pieces.~~

SC-205.C.3.a. delete:

- ~~2. Horses must be shown in a regulation hunt snaffle bit with mouth piece as follows: Bars of mouthpiece must be round, smooth and unwrapped metal no less than 5/16 inch (.79cm) in diameter measured one inch in from cheek with a gradual decrease to the center of the snaffle. May be inlaid, but smooth, or rubber latex wrapped. The mouthpiece may be three pieces.~~

SC-205.C.3.b. delete:

- ~~2. Horses must be shown in a regulation hunt snaffle bit with mouth piece as follows: Bars of mouthpiece must be round, smooth and unwrapped metal no less than 5/16 inch (.79cm) in diameter measured one inch in from cheek with a gradual decrease to the center of the snaffle. May be inlaid, but smooth, or rubber latex wrapped. The mouthpiece may be three pieces.~~

Replace all of the above rules with:

Horses may be shown in a regulation hunt snaffle bit. No mouth pieces can be wrapped in metal. No square stock steel can be used. Slow twists, corkscrew, double and single twisted wires may be used if they are 5/16" in diameter to be measured 1" from the cheek or ring. Bits may be broken in more than one place. No bit with leverage such as Kimberwicks, pelhams, Mylars, or any bit with shanks, a curb chain, or reins attached to the bit, can be used in either the two or three year old hunter under saddle.

Control SC-241 (sent to task force)

Rule SC-241. C., addition to read.

C. Lope. Lope, an easy, rhythmical, clean three-beat gait. Horses moving...is a natural way of going. Loping with the haunches in (toward the center of the arena) **and headbobbing** must be penalized. See Rule SC-245. For more specific Western Pleasure gait descriptions.

Control SC-245-1 (sent to task force)

Rule SC-245. H. addition to read.

H. RING PROCEDURE.

1. Walk, Jog and Lope. Horses are to be shown at a walk, jog and lope on a reasonably loose rein without undue restraint. It is mandatory that a moderate extension of the jog be asked for in at least one direction during the Western Pleasure classes. **The judge is required to ask for a lengthening of stride at either the walk or lope when he/she sees one of these faults in the class: interrupted walks—a walk with pauses or breaks in the four-beat-rhythm or horses loping with negative characteristics such as head bobbing, overly canted dwelling on the outside front leg or lacking cadence.** Exceptions: 2-Year Old Western Pleasure...Judge may at his discretion, back only the finalists.

Control SC-245-2 (sent to task force)

Rule SC-245. H., addition to read.

H. RING PROCEDURE.

1. Walk, Jog and Lope. Horses are to be shown at a walk, jog and lope on a reasonably loose rein without undue restraint, **with light contact and control; light contact should be measured by a horse's response to the rider's hands, seat and legs and not merely by the tension in the reins. However, an excessively draped rein is just as undesirable as an extremely tight rein. Subtle cues are desirable, while an absence of cues is not. The individual that willingly and quietly responds to subtle cues by the rider is performing with light contact.** It is mandatory that a moderate extension of the jog be asked for in at least one direction during the Western Pleasure classes. Exceptions: 2-Year Old Western Pleasure...Judge may at his discretion, back only the finalists.

Control SC-245-3 (sent to task force)

Rule SC-245. H., addition to read.

H. RING PROCEDURE.

1. Walk, Jog and Lope. Horses are to be shown at a walk, jog and lope on a reasonably loose rein without undue restraint, **with light contact and control; light contact should be measured by a horse's response to the rider's hands, seat and legs and not merely by the tension in the reins. However, an excessively draped rein is just as undesirable as an extremely tight rein.** It is mandatory that a moderate extension of the jog be

asked for in at least one direction during the Western Pleasure classes. Exceptions: 2-Year Old Western Pleasure...Judge may at his discretion, back only the finalists.

Control SC-245-4 (sent to task force)

Rule SC-245. J.3.a., change to read.

a. Evaluation

1. A horse exhibiting an Excellent Lope rounds his/her back and has a strong deep stride and a flat swing with his/her front legs. He/she swings his/her legs correct and long, yet seems to do it effortlessly with a soft stride. His/her hocks do not drift behind into his/her tail. He/she maintains a very level top line, along with a relaxed, yet alert and confident appearance. He/she has ~~a great degree of~~ **good** lift and self carriage. **An excellent looper does not bob his head and is not canted (haunches in toward the center of the arena).**

Control SC-245-5 (sent to task force)

Rule SC-245. J.3.a., addition to read.

a. Evaluation

1. A horse exhibiting an Excellent Lope rounds his/her back and has a strong deep stride and a flat swing with his/her front legs. He/she swings his/her legs correct and long, yet seems to do it effortlessly with a soft stride. His/her hocks do not drift behind into his/her tail. He/she maintains a very level top line, along with a relaxed, yet alert and confident appearance. He/she has a great degree of lift and self-carriage. **An excellent looper has very little head and neck motion and is not canted (haunches in toward the center of the arena).**

Control SC-245-6 (sent to task force)

Rule SC-245. F., addition to read.

- F. A Western Pleasure horse should be a pleasure to ride. He/she should exhibit a free flowing stride with natural lift and self-carriage, along with smooth gaits and transitions. Emphasis shall be placed on good movers, manners and a willing attitude, as reflected in the horse's ears, mouth, tail and way of going; any attempt to alter these attributes shall be severely penalized. Credit should be given for performing ~~with a degree of difficulty~~ as described as good, very good or excellent in the **more specific western pleasure** gait evaluations under J below.

Control SC-245-7 (sent to task force)

Rule SC-245., change to read.

K. Faults. To be scored according to severity. 1-9 remain the same.

10. Failure to maintain a reasonably loose rein without undue restraint **or if reins are draped to the point that light contact is not maintained.**

11-18. remain the same.

Control SC-245-8 (sent to task force)

Rule SC-245., change to read.

K. Faults. To be scored according to severity. 1-18 remain the same.

- 19. Excessive bobbing of the head at the lope caused by lack of forward motion (horse going too slow).**

Control SC-245-9 (sent to task force)

Rule SC-245.K.17, change to read.

~~17. Overly canted at the lope. Horses which lope with haunches in (toward center of arena).~~

- 17. Overly canted at the lope/canter. (Outside hind leg consistently carried further in than inside front leg).**

Control SC-250 (sent to task force)

Rule SC-250. H. Addition to read.

- H. OBSTACLE REQUIREMENTS.** Course will include a minimum of 6 and a maximum of 10 obstacles and must be designed using at least one obstacle from each of the following divisions. **Each obstacle can only be used once on the course (i.e., lope-over, trot-over, etc.)**

Control SC-250-1 (sent to task force)

Rule SC-250., delete ~~Trail~~ and change to Obstacle Course.

Western Tack & Attire: See Western Pleasure (SC-235 & SC-240)

A. Exhibitor Requirements:

- 1. Exhibitor may use only one hand on the reins and hands may not be changed except when:**
 - a. Putting on or removing slicker.**
 - b. Carrying an object from one part of the arena to another.**
 - c. Dismounting.**

B. Judging Procedures. This class will be judged 100% on manner of performance of the horse over obstacles, response to the rider, intelligence and manner of travel at the walk, trot, and lope should be performed as the horse moves from one obstacle to the next giving the judge an opportunity to evaluate all three gaits somewhere within the ~~trail~~ obstacle course. Example: The horse could walk from first to second obstacle, trot from second to third, and lope from third to fourth obstacle.

C. Scoring System. Scoring will be on the basis of infinity, with 70 denoting an average performance. Each obstacle will receive an obstacle score that should be added or subtracted from 70 and is subject to a penalty that should be subtracted.

D. Each obstacle will be subtracted. Each obstacle will be scored on the following basis, ranging from plus 1 ½ to minus 1 ½, -1 ½ extremely poor, -1 very poor, ½ poor, 0 correct, +1/2 good, +1 very good, +1 ½ excellent. Obstacle scores are to be determined and assessed independently of penalty points. Credit will be given to those horses negotiating

the obstacles cleanly, smoothly, and alertly with style in prompt response to the rider's cues. Penalties should be assessed per occurrence as follows:

1. One half (1/2) POINT
 - a. Each tick of log, pole, cone or obstacle.
 2. One (1) POINT.
 - a. Each hit of or stepping on a log, pole, cone or obstacle..
 - b. Incorrect or break of gait at walk or jog for two strides or less.
 - c. Both front or hind feet in a single-strided slot or space at a walk.
 3. Three (3) POINTS.
 - a. Incorrect or break of gait at walk or jog for more than 2 strides.
 - b. Out of lead or break of gait at lope (except when correcting an incorrect lead.)
 - c. Stepping outside the confines of, failing or jumping off or out of an obstacle with designated boundaries with one foot once the foot has entered obstacle, including missing one element of an obstacle on a line of travel with one foot.
 4. Five (5) POINTS.
 - a. Dropping slicker or object required to be carried on course.
 - b. First or second cumulative refusal, balk, or evading an obstacle by shying or backing.
 - c. Letting go of gate.
 - d. Use of either hand to instill fear or praise.
 - e. Stepping outside the confines of, falling or jumping off or out of obstacle with designated boundaries with more than one foot once the foot has entered obstacle; including missing one element of an obstacle on a line of travel with more than one foot.
 - f. Blatant disobedience (including kicking out, bucking, rearing, striking.)
- E. Obstacle Requirements:
1. Six to Eight obstacles will be used, the three mandatory obstacles and three to five additional obstacles selected from the optional list.
 2. Care must be exercised to avoid the setting up of any of these obstacles in a manner that may be hazardous to the horse or rider. Obstacles not combined shall be a minimum of nine feet apart.
 3. The Trail obstacle course must be outlined by the show management and posted one hour prior to the class for the information of the contestants and the judge.
 4. Where the local conditions and equipment will not permit the establishment of obstacles as specified and that they may require changing of hands on the reins, then all competitors must be advised that such changing of procedures or of hands is permitted.
- F. Mandatory Obstacles:
1. Gate. The gate must be set up so that it is a minimum of four feet in length and four feet in height and so that the contestant can open from his right side or his left side. The rider may not change hands or lose control of the gate while passing through.
 2. Bridge. A bridge with a wooden floor not to exceed twelve inches in height and with or without side rails not less than thirty inches apart will be used. A log placed under

the bridge to create a teeter-totter effect is not prohibited so long as it is secured to the bridge so as not to shift during passage of the horse over the bridge.

3. Demonstrate BACKING through any one of the following patterns.
 - a. The "L". Back horse through "L" shaped course. Smooth parallel pole laying on the ground not less than thirty inches apart and not less than ten feet on each side of the "L" will be established.
 - b. Triangle. 3 barrels or cones set in a triangle pattern as per diagram.

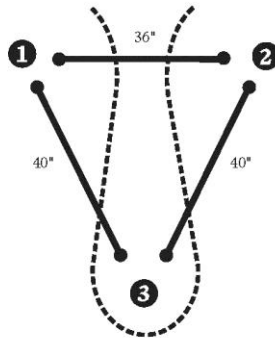

Horses to back through first two markers, around center marker and back through first two markers to starting point. Distance between marker 1 and 2, 36 inches. Distance between 3 and 1, 3 and 2, 40 inches.

- c. Figure 8: 3 barrels or cones set in a straight line as per diagram.

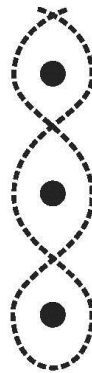

Horses to pass to the outside of barrel one, cross over to the outside of barrel two, cross over the outside of barrel three, to around and reverse procedure, back to starting point. Distance between barrels 1, 2, and 3 is 36 inches.

- d. Box Back: 4 poles, six to eight feet long.

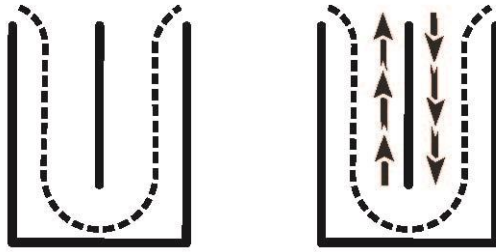

Place poles as per diagram. Center pole to be halfway between two parallel poles and 36 inches from connection pole. Horse to start back between center pole and side pole, around center pole and back to starting point. Alternative to this is to start back between center pole and side pole, when horse is parallel to connecting pole, side pass center pole both ways, and complete back as described in first pattern.

G. Optional Obstacles.

1. **Water Hazard.** A ditch or shallow pond of water may be used. A horse must pass through this obstacle which must be large enough so that to properly complete this obstacle, all four feet of the horse must step in the water.
2. **Simulated Water.** A plastic sheet, secured to the ground that it will not become affixed to the horse's foot and move away when a horse passes over the simulated water, may be used.
3. **Carry Object.** Any object other than animal or fowl, and reasonable size or weight may be carried to a specific point.
4. **Ground Tie.** Rider to proceed to the designated place, dismount and either hobble or ground tie his horse and move away from the horse a reasonable distance to clearly show the proper training of the horse.
5. **Barrels.** Two or three spaced at least forty inches apart through which exhibitor is to back.
6. **Slicker.** When this obstacle is used, it will be so located that the rider can ride to the slicker, put it on and remove it and return it to a designated place. Reins may be held or dropped on the neck of the horse or over the saddle horn while so doing.
7. **Logs.** An obstacle of at least four smooth logs placed at least 18 to 24 inches apart in such a manner as to demonstrate the willingness of the horse to proceed over such obstacles. Walk-Over logs placed 18 to 24 inches apart.
8. **Barricades.** An obstacle not less than fourteen inches high or more than twenty-four inches high may be designed for horses to be ridden over or led over and whichever way is selected to be specified in the design of the course.
9. **Side Pass.** An object such a nature and length which is safe and laying on the ground may be used to demonstrate the responsive ness of the horse to leg signals. Objects such as a bale of hay that may become entangled in a horse's feet or legs will not be used. The obstacle may be designed to require the horse to side pass either or both ways or in a pattern.
10. **Mail Box.** Side pass to and away from the mail box.

11. Lime Circle. Requiring turn on forehand with front feet inside and back feet turning on to side of lime circle.
12. Sheep Pen. Or Cattle Pen. Ride by.
13. Cowhide. Either ride over or next to cowhide.
14. Square. Ride into, turn completely on forehand and ride out.
15. Drag or Pull. Any object other than animal or fowl which can reasonably be pulled without the contestant having to dally may be used. Dally shall be at the option of the exhibitor.

In a show where Open, Youth and Amateur ~~trail~~ obstacles classes are offered, all the optional obstacles for Open, Youth and Amateur ~~trail~~ obstacle courses must be different or manner of performance over obstacles must be varied.

Control SC-289 (sent to task force)

Rule SC-289., new Rule to read. Speed Events Dual-Approved As APHA Special Events.

- A. For speed events that are dual-approved as APHA-approved Special Events and held concurrently with another all-breed organization (e.g. NBHA Barrel Racing dual-approved as an APHA Special Event), the following rules apply:
 1. Timing officials may be used in place of APHA Judges as per Rule JU-000.C. Officials must be approved by the National Barrel Horse Assn. (NBHA) and/or other recognized speed event organization that has been approved by the APHA.
 2. As long as the pattern around the obstacles matches APHA rules, the course set-up including distance between obstacles may be based on the rules of the NBHA or National Saddle Clubs Association (NSCA).
 - a. A copy of the show's rules must accompany the APHA Special Event application and be approved by the APHA.

RELATED RULES:

JU-000., addition to read. Judge Rules and Regulations

C. SPECIALTY JUDGES.

1. APHA will approve specialty judges in the following classes:
 - a. Working Cow Horse (NRCHA)
 - b. Reining (NRHA)
 - c. Team Penning, Ranch Sorting (USTPA)
 - d. Jumping, Equitation Over Fences, Working Hunter, Hunter Hack (USEF)
 - e. Cutting (NCHA)
 - f. Barrel Racing, **Pole Bending, Stake Race (NBHA and/or other recognized speed event organizations that have been approved by the APHA)**
 - g. Stock Horse of Texas/American Stock Horse Association (SHOT/ASHA)
 - h. Cowboy Mounted Shooting Association (CMSA)

Control SC-290 (sent to task force)

Rule SC-290., change to read. Barrel Racing.

D. 4. b. Delete and replace with:

- b. Hats or safety helmets are recommended for this class, but are at the exhibitor's option. If hat or safety helmet is worn and it falls off and touches the ground while in the arena, a five (5) second penalty will be assessed.

Control SC-290-1

SC-290. G. Barrel Racing Pattern

If dual approval is warranted, measurement to be changed according to the size of the arena.

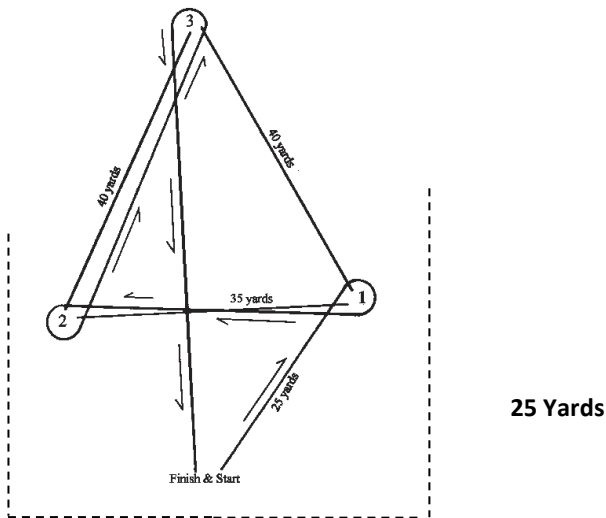

Control SC-295 (sent to task force)

Rule SC-295. C. 3., delete and replace with. Pole Bending.

- c. 3. Hats or safety helmets are recommended for this class, but are at the exhibitor's option. If hat or safety helmet is worn and it falls off and touches the ground while in the arena, a five (5) second penalty will be assessed.

Control SC-296-1 (sent to task force)

Rule SC-296., delete and replace C. 1. Stake Race.

- C. 1. Hats or safety helmets are recommended for this class, but are at the exhibitor's option. If hat or safety helmet is worn and it falls off and touches the ground while in the arena, a five (5) second penalty will be assessed.

Control JU-000 (sent to task force)

Rule JU-000.I., add new 3. And renumber accordingly.

3. Reasons. Reasons shall be given in at least 2 classes at each show. A different judge shall give reasons on classes selected by show management. Show management shall select

7/18/2013 1:37:07 PM

the judge to give reasons. Reasons will be given for top six placings only. (Exception: APHA Sponsored Shows.)